



SCOPE OF WORK **CITY OF SOUTH BEND**

PROJECT NAME: PW Service Center Salt Dome Roof Replacement

PROJECT NO. R126-021

QUOTES DUE 9am EDT – June 9th, 2026 to bpwbids@southbendin.gov

I. PROJECT DESCRIPTION

- A. The project includes the furnishing of all equipment, material, insurance, and labor for the **salt dome roof replacement at 731 S. Lafayette Blvd** within the City of South Bend, IN.

II. PREVAILING SPECIFICATIONS AND CONSTRUCTION STANDARDS AND SPECIFICATIONS

- A. The City of South Bend's **PREVAILING SPECIFICATIONS**, most recent version, and **CONSTRUCTION STANDARDS AND SPECIFICATIONS**, most recent version, are to be used on this project.
- B. Each Quote provider is specifically instructed to become completely familiar with the most recent version of the **PREVAILING SPECIFICATIONS** and the **CONSTRUCTION STANDARDS AND SPECIFICATIONS** prior to submitting a quote.
- C. Wherever the **PREVAILING SPECIFICATIONS** refer to "State Specifications," it shall mean the 2026 INDOT Standard Specifications for the letting effective after September 1, 2025.
- D. These **SPECIAL PROVISIONS** will list only "Additions" or "Deletions" to the **PREVAILING SPECIFICATIONS** and are to be used only in conjunction with the **PREVAILING SPECIFICATIONS**.
- E. In the event of conflict between the **SPECIAL PROVISIONS** and the **PREVAILING SPECIFICATIONS**, the **SPECIAL PROVISIONS** will govern.

III. TERM "OR EQUAL"

- A. Prevailing Specifications: None
- B. Additions

1. Where the term "or equal" is used in these specifications, the Quote provider deviating from specified item shall file with his/her/its Quote a letter fully explaining and justifying his/her/its proposed article or equal. The City of South Bend shall be the sole judge in determining if the "or equal" offered meets the specification.

IV. TAX EXEMPT

- A. Prevailing Specifications: None
- B. Additions

1. Materials and properties purchased under contract with the Owner that become a permanent part of the structure or facilities constructed are not subject to the Indiana Gross Retail Tax (Sales Tax). The exemption number will be furnished to the Contractor upon award.

V. INDEMNIFICATION

- A. Prevailing Specifications: None
- B. Additions

1. Contractor agrees to indemnify, defend and hold harmless the City of South Bend, its agents, officers and employees, from all costs, losses, claims and suits, including court costs, attorney fees, and other expenses, arising from or out of the negligent performance of this Contract by Contractor, or because of arising out of any defect in the goods, materials or equipment supplied by the Quote provider.

VI. INSURANCE

- A. Prevailing Specifications: 2026, INDOT Standard Specifications Section 103
- B. Additions:

1. All Contractors and subcontractors doing business with the City of South Bend shall present a Certificate of Insurance showing coverage in the following minimum amount:
 - a. General Liability: Premises-Completed Operations or Products, Bodily Injury and Property Damage Combined Single Limit - \$5,000,000.
 - b. There shall be no exclusion for explosion, collapse or underground hazard.
 - c. Workmen's Compensation: Statutory State of Indiana Employer's Liability - \$100,000.
 - d. Auto Liability: Bodily Injury and Property Damage Combined Single limit - \$1,000,000.
 - e. The City of South Bend shall be named as additional insured on the Certificate of Insurance.

VII. CONTROL OF WORK

- A. Prevailing Specifications: 2026, INDOT Standard Specifications Section 105
- B. Additions:

1. The complete responsibility for this project lies with the Director of Public Works of the City of South Bend, Indiana acting through his authorized representatives.
2. Construction Engineering - The Contractor shall provide all the necessary, qualified personnel, equipment and supplies to perform all work required under this item. There will be no direct payment for this item.
3. The contractor is responsible for maintaining the site, which includes, but is not limited to, dust control, site security, erosion control, and protecting adjacent properties.
4. Work hours for the Project shall be from 7:00 a.m. through 6:00 p.m., Monday through Friday. No work shall be permitted on weekends, Holidays, or after hours unless approved by the City of South Bend Department of Public Works.

VIII. LEGAL RELATIONS

- A. Prevailing Specifications: 2026, INDOT Standard Specifications Section 107
- B. Additions:

1. The Owner, where mentioned in these documents, is the City of South Bend. The Engineer, where mentioned in these documents, is **City of South Bend**.
2. The Contractor shall apply for and obtain any and all required permits for the work from local, state, and federal agencies and shall comply with permit requirements, including the St. Joseph County / City of South Bend Building Department.
3. If the Contractor awarded this contract is not a resident of Indiana, within thirty days, the Contractor shall provide the Owner with proof that the Contractor is duly licensed, qualified and registered with the Secretary of State of Indiana to engage in business within the State of Indiana.
4. The Contractor shall comply with all provisions of Indiana Code 5-16-13, as amended. The Owner reserves the right to immediately terminate the public work project awarded should the Contractor be found to be in violation of any provision of Indiana Code 5-16-13 and such violation shall result in the forfeiture of Contractor's performance bond to the Owner.

IX. PROSECUTION AND PROGRESS

- A. Prevailing Specifications: 2026, INDOT Standard Specifications Sec. 108
- B. Additions:

1. The project will have a completion date of **45 calendar days**. The contract time will start when the Notice to Proceed is delivered and signed.
2. The City, Engineer, and Contractor will hold a pre-construction meeting following award of the contract. The date of the Notice to Proceed will be agreed at that meeting.
3. Contractor shall provide a schedule to the Owner prior to beginning any work on the site.

4. The Contractor shall utilize the City of South Bend selected project management software for reporting of all activities related to the contracted work.

X. CHANGE OF CONTRACT TIME

- A. Prevailing Specifications: 2026, INDOT Standard Specifications Section 108
- B. Additions

1. The Contract Time may only be changed by Change Order. Any Claim for an extension in the Contract Time shall be based on written notice delivered to the Department of Public Works within seven (7) calendar days of the occurrence of the event giving rise to the claim. Notice of the extent of the claim with supporting data shall be delivered within fourteen (14) calendar days after such occurrence unless an official of the Public Works Department allows an additional period of time to ascertain more accurate data. The Contract Time will be extended in an amount equal to time lost to delays beyond the control of the Contractor if a claim is made in accordance with this provision. Such delays shall include acts of neglect by the Public Works employees, or to fires, flood, labor disputes, epidemics, abnormal weather conditions, governmental procedures, or acts of God.
2. Unless otherwise provided, the Contract time is based upon normal weather conditions. An extension is granted for weather conditions significantly more severe than normal if the Contractor demonstrates to the satisfaction of the City that the delay in the progress of the work was due to such weather. The basis to define normal weather will be the data compiled by the United States Department of Commerce, National Oceanic and Atmospheric Administration (NOAA).
3. No extension of time will be granted if the Contractor, by his/her/its own action or inaction, including fault or negligence of Contractor's subcontractors, caused the delay, or for which any remedies are provided under any other provision of this agreement.
4. The grant of an extension of time under this Section in no way constitutes a waiver by the City of any rights or remedies existing under this contract at law or in equity.

XI. DEFAULT AND TERMINATION

- A. Prevailing Specifications: 2026, INDOT Standard Specifications Section 108
- B. Additions:

1. Events of Default shall include Contractor's failure to perform any of its obligations under this contract including failure to commence work at the time specified, failure to perform the work in accordance with these specifications, unauthorized discontinuation of the work, failure to carry out the work in a manner acceptable to the City, failure to observe Federal, State, or local laws or regulations, and failure to comply with any other term of this contract.
2. If an Event of Default occurs, the City shall provide Contractor written notice and may permit Contractor ten (10) calendar days after the date of the notice to cure the default. If the default is not cured within the ten (10) day cure period, the City may at any time thereafter terminate this contract in which case the termination shall be final and effective.
3. Upon an Event of Default, the City may invoke the following remedies in addition to those remedies provided under separate provisions of this contract, the right of set-off against any payments due or to become due to the Contractor against the retainage, the right to take over and complete the Work. If the City notifies Contractor that City is invoking its right to complete the Work, all rights that the Contractor has in order under Contractor's subcontracts are assigned to the City, subject to the City's right to take assignment of all or only selected subcontracts at the City's discretion. The sole obligation accepted by the City under such subcontracts is to pay for Work satisfactorily performed after the date of the assignment. In the event a conditional assignment has not been executed, the Contractor shall execute or cause to be executed any assignment, agreement, or other document that may be necessary in the sole opinion of legal counsel to the City's Board of Public Works to evidence compliance with this provision. The Contractor shall promptly deliver such documents upon the City's request. In the case of such assignment, unless otherwise agreed in writing, The Contractor remains liability to subcontractors for any payment already involved, and for any claim, suit or cause of action based upon or resulting from any error, omission, negligence or other breach of contract by the Contractor, its officers, employees, or agents arising prior to the date of assignment to the City.

XII. LIQUIDATED DAMAGES

- A. Prevailing Specifications: 2026, INDOT Standard Specifications Section 108
- B. Additions:

1. The contractor shall proceed with the work at such rate of progress to insure full completion within the Contract Time. It is expressly understood and agreed, by and between the Contractor and the Owner, that the Contract Time for completion of the work described herein is a reasonable time, taking into consideration the average climatic and economic conditions and other factors prevailing in the locality of the work, and excludes the time for unavoidable delays which were beyond the control and without the fault of the Contractor.
2. If the Contractor shall fail to complete the work within the Contract Time, or extension of time granted by the Owner, then the Contractor will pay to the Owner the amount for liquidated damages a sum of five hundred dollars (\$500.00) for each calendar day that the Contractor shall remain in default after the time of completion stipulated in the Contract Documents.
3. The Contractor shall not be charged with liquidated damages or any excess cost when the delay in completion of the work is due to the following and the Contractor has promptly given written notice of such delay to the Owner and Engineer/Architect.
 - a. To any preference, priority, or allocation order duly issued by the Owner.
 - b. To unforeseeable causes beyond the control and without the fault or negligence of the Contractor, including but not restricted to acts of God, acts of public enemy, acts of the Owner, acts of another Contractor in the performance of a Contract with the Owner, fires, floods, epidemics, quarantine restrictions, strikes, freight embargoes, and abnormal and unforeseeable weather.

XIII. RETAINAGE AND FINAL PAYMENT

- A. Prevailing Specifications: 2026, INDOT Standard Specifications Section 109
- B. Additions:

1. Payments will be made every thirty (30) calendar days
2. Consistent with provisions of IC 36-1-12-14, the Board of Public Works shall withhold five percent (3%) of the dollar value of all work satisfactorily completed until the public work is substantially completed and the Project Completion Affidavit is approved by the Board.
3. Before final payment and retainage are released the Contractor must satisfy the following:
 - a. Provide proof that all subcontractors have been paid promptly, including fully documenting payments in the City's Minority and Women Owned Business utilization tracking software B2G Now. See www.southbend.diversitycompliance.com.
 - b. All parts and labor meet requirements stated in the specifications.
 - c. Provide copies of test reports or cut sheets on all materials supplied.
 - d. Provide As-Built drawings in accordance with the City of South Bend Prevailing Specifications for Public Works.
 - e. One (1) copy of the City of South Bend Completion Affidavit and one (1) copy of a Final Waiver of Lien.

XIV. WARRANTY

- A. Prevailing Specifications: None
- B. Additions

1. All Parts shall include the following:
 - a. Performance specifications
 - b. Bill of Materials
 - c. Warranties on all parts
 - d. Installation and safety requirements

XV. OTHER UTILITIES

- A. Prevailing Specifications: None
- B. Additions:

1. The Contractor shall verify the locations of all utilities by contacting Indiana811 by calling 811 (in Indiana) or 1-800-382-5544 (outside of Indiana), or via www.indiana811.org, at least two (2) working days, not counting Saturdays, Sundays or federal and state holidays before proceeding with construction. It shall also be the Contractor's responsibility to contact any other utility that is not contacted by Indiana811 and verify the utility locations.
2. The Contractor shall be responsible for working with the other utilities, i.e., gas electric, telephone, etc. in order to assure that all utilities that need to be replaced or relocated can be done with a minimum disturbance to service. The Contractor shall also be responsible for coordinating schedules with the various utilities such that they can proceed with their relocation work as efficiently as possible.
3. If the odor of natural gas is detected in a work area at any time during the course of work, the Contractor shall immediately notify NIPSCO at 1-800-634-3524. The Contractor shall also immediately notify the residents of adjacent properties. The Contractor shall advise the residents to evacuate their homes immediately if the odor is present within the dwelling.
4. Restoration of sprinkler systems damaged by the Contractor's operations shall be repaired by the Contractor at no additional cost to the City or the Owner of the system.

XVI. MAINTENANCE OF TRAFFIC

- A. Prevailing Specifications: 2026, INDOT Standard Specifications Sections 105 & 801
- B. Additions:

1. Maintenance of traffic during construction shall conform to the "Indiana Manual on Uniform Traffic Control Devices" and the City of South Bend Design and Construction Standards.
2. The attached "Traffic Closure Request" form is to be used for any lane restrictions or closures and required to be filled out and sent to the Department of Public Works
3. The Contractor shall arrange and prosecute the work specified for this contract in such a manner that traffic on existing streets is unrestricted throughout the Project. The Engineer shall approve the method of traffic control. No construction equipment, vehicles, materials, supplies or temporary facilities shall be left unattended in the right-of-way of any street or left parked overnight without proper marking and lighting.
4. After the award of the contract and before beginning the work, the Contractor shall submit his/her/its proposed schedule of operations for the review of the Engineer. The schedule of operations as reviewed by the Engineer shall be maintained at all times.
5. There will be no direct payment for this work.

XVII. DESCRIPTION OF WORK

- A. Prevailing Specifications: None
- B. Additions

1. Work to be performed shall include furnishing all labor, services, materials, insurance and equipment to **removal of existing asphalt shingle roof and installation of new shingle roof system at Public Works Service Center Salt Dome** within the City of South Bend.
2. The Contractor shall preserve and protect all surrounding property, structures, tenants, visitors and their property from damage caused by the Contractor's operations.

XVIII. ROOF REPLACEMENT

- A. Prevailing Specifications: None
- B. Additions:

1. Remove existing asphalt shingle system and underlayment and prepare for new installation with a ½" sheathing overlay and roof underlayment. Infill any missing or decayed existing roof sheathing with matching solid wood prior to sheathing overlay.

2. Synthetic underlayment for the felt, ice, and water shields shall be used and installed according to the local building code. Install ice and water shield along the entire bottom edge.
3. Where gaps are present in the lumber beneath the decking, 1" by 4" standard, solid lumber shall be cut to fit and replace the decaying lumber prior to sheathing overlay.
4. The metal drip edge shall be replaced with aluminum and new material shall come past the roof deck.
5. Contractor shall verify the deck condition and replace all bad decking with new.
6. Contractor shall verify slope and install underlayment if slope is <4:12
7. Contractor shall use self-adhered ice and water membrane at eaves and transitions.
8. Contractor shall install metal flashings at joints and penetrations.
9. Contractor shall install new roof vents and new pipe flashing.
10. All fasteners, flashing, and exposed metal components shall be stainless steel or hot-dip galvanized, suitable for high-chloride environments.

XIX. PLANS

- A. Prevailing Specifications: City of South Bend Design and Construction Standards
- B. Additions:
 1. The plans consist of **zero** Sheets. All information is contained within this document.
 2. The CONTRACTOR is responsible for estimating dimensions and quantities of materials.
 3. In the event that the Special Provisions and the Plans conflict, the Special Provisions shall govern.

XIX. M/WBE GOALS

- A. Prevailing Specifications: City of South Bend Ordinance No. 10761-21, Minority and Women Business Enterprise Inclusion Program Plan
- B. Additions:
 1. The M/WBE Goals for this Project are
 - a. MBE 0.6%.
 - b. WBE 2.1%.
 2. Complete M/WBE Checklist included in these bid documents, including Evidence of Good Faith Efforts Forms [MBE-2.0 and WBE-2.0] and M/WBE Contacted Forms [MBE-2.1 and WBE-2.1] if applicable, and submit with Bid Proposal.
 3. ***Goals shall be calculated based on the Base Bid only.***

**CITY OF SOUTH BEND, INDIANA
CONTRACTOR'S QUOTE FOR PUBLIC WORK**



PROJECT NAME: PW Service Center Salt Dome Roof Replacement
PROJECT NO. R126-021
QUOTES DUE 9am EDT – June 9th, 2026 to bpwbids@southbendin.gov

(Must be completed for all quotes. Please type or print)

Date: 6-8-2026 Firm: Alice Homes LLC
Address: 12900 Coldwater Drive
City/State/Zip: Evansville, IN 47725 Telephone Number: () 812-480-7021
Email Address: info@alicehomesllc@gmail.com

Agent of Bidder (if Applicable): _____
Pursuant to notices given, the undersigned offers to furnish labor and/or material necessary to complete the public works project of:

Public Works Service Center Salt Dome Roof Replacement

the City of South Bend, Indiana, in accordance with plans and specifications prepared by:

The City of South Bend, Department of Public Works

and dated May 12th, 2026 for the sum of (enter the Total Quote as shown on the Proposal)

_____ (\$ 249,658.62)
(Enter Sum of Total Quote plus Alternates shown on Proposal) (Numerical)

If alternative quotes apply, the undersigned submits a proposal for each in accordance with the notice. Any addendums attached will be specifically referenced at the applicable page.

If additional units of material included in the contract are needed, the cost of units must be the same as that shown in the original contract if accepted by the City of South Bend. If the quote is to be awarded on a unit basis, the itemization of the units shall be shown on a separate attachment.

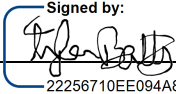
By _____

22256710EE094A8... (Signature)
Tyler Batty
(Printed Name of Person Signing)

ACCEPTANCE

The above quote is accepted this _____ day of _____ 20 _____

Subject to the following conditions: _____

BOARD OF PUBLIC WORKS

President

Members

CITY OF SOUTH BEND

EQUAL EMPLOYMENT OPPORTUNITY CONTRACTING PROVISIONS DIVERSITY UTILIZATION

It is the policy of the City of South Bend to provide equal employment and business opportunity for all persons, partnerships, companies, and corporations in accordance with the rules, regulations and guidelines of the applicable federal, state and local laws. This policy of equal employment and business opportunity shall apply to every contractor or subcontractor bidding or holding a public contract with the City of South Bend.

In furtherance of this policy, the following Equal Opportunity Clauses are hereby made a part of every construction contract entered into by the City of South Bend and all subcontractors entered into pursuant to any such contract and the bidder hereby certifies that it/he/she will abide by these provisions.

The contractor will not discriminate against any applicant or employee because of race, color, religion, sex, national origin, or handicap. The contractor will take affirmative action to ensure that all applicants or employees are treated fairly and equitably. Such action shall include but not be limited to the following: hiring, up-grading, demotion or transfer, recruitment, advertising, lay-offs or termination, rates of pay or other forms of compensation and selection for training including apprenticeship programs.

The contractor shall agree to post in conspicuous places available to employees and applicants, notices to be provided setting forth the provisions of the Non-Discrimination Clause.

The contractor will, in all solicitations or advertisements for employees placed by or on behalf of the contractor, state that all qualified applicants will receive consideration for employment without regard to race, color, religion, sex, or national origin.

The contractor will send to each labor union or representative of workers with which it/he/she has a bargaining agreement or other contract or understanding, a notice to be provided, advising the labor union or worker's representatives of the contractor's commitment under this section, and shall post copies of the notices in conspicuous places available to applicants and employees.

The contractor will comply with all provisions of Executive Order 11246 (as amended by 11375) and of the rules, regulations and relevant orders of the Department of Labor.

Subpart B -- Contractors' Agreements

Sec. 202. Except in contracts exempted in accordance with Section 204 of this Order, all Government contracting agencies shall include in every Government contract hereinafter entered into the following provisions:

"During the performance of this contract, the contractor agrees as follows:"

"(1) The contractor will not discriminate against any employee or applicant for employment because of race, color, religion, sex, or national origin. The contractor will take affirmative action to ensure that applicants are employed, and that employees are treated equally during employment, without regard to their race, color, religion, sex or national origin. Such action will include, but not be limited to the following: employment, upgrading, demotion, or transfer; recruitment or recruitment advertising; layoff or termination; rates of pay or other forms of compensation; and selection for training, including apprenticeship. The contractor agrees to post in conspicuous places, available to employees and applicants for employment, notices to be provided by the contracting officer setting forth the provisions of this nondiscrimination clause."

"(2) The contractor will, in all solicitations or advertisements for employees placed by or on behalf of the contractor, state that all qualified applicants will receive consideration for employment without regard to race, color, religion, sex or national origin."

"(3) The contractor will send to each labor union or representative of workers with which it/he/she has a collective bargaining agreement or other contract of understanding, a notice, to be provided by the agency contracting officer, advising the labor union or workers' representative of the contractor's commitments under Section 202 of Executive Order No. 11246 of September 24, 1965, and shall post copies of the notice in conspicuous places available to employees and applicants for employment."

"(4) The contractor will comply with all provisions of Executive Order No. 11246 of September 24, 1965, and of the rules and regulations, and relevant orders of the Secretary of Labor."

"(5) The contractor will furnish all information and reports required by Executive Order No. 11246 of September 24, 1965, and by the rules, regulations, and orders of the Secretary of Labor, or pursuant thereto, and will permit access to his books, records, and accounts by the contracting agency and the Secretary of Labor for purposes of investigation to ascertain compliance with such rules, regulations, and orders."

"(6) In the event of the contractor's noncompliance with the nondiscrimination clauses of this contract or with any of such rules, regulations, or orders, in this contract may be cancelled, terminated or suspended in whole or in part and the contractor may be declared ineligible for further Government contracts in accordance with procedures authorized in Executive Order No. 11246 of September 24, 1965, and such other sanctions may be imposed and remedies invoked* as provided in Executive Order No. 11246 of September 24, 1965, or by rule, regulations, or order of the Secretary of Labor, or as otherwise provided by law."

"(7) The contractor will include the portion of the sentence immediately preceding paragraph (1) and the provisions of paragraphs (1) through (7) in every subcontract or purchase order unless exempted by rules, regulations, or orders of the Secretary of Labor issued pursuant to Section 204 of Executive Order 11246 of September 24, 1965, so that such provisions will be binding upon each subcontractor or vendor. The contractor will take such action with respect to any subcontract or purchase order as the administering agency may direct as a means of enforcing such provisions including sanctions for noncompliance: Provided, however, that in the event a contractor becomes involved in, or is threatened with, litigation with a subcontractor or vendor as a result of such direction by the administering agency the contractor may request the United States to enter into such litigation to protect the interests of the United States."

The applicant further agrees that it will be bound by the above equal opportunity clause with respect to its own employment practices when it participates in federally assisted construction work: Provided, that if the applicant so participating is a State or local government, the above equal opportunity clause is not applicable to any agency, instrumentality or subdivision of such government which does not participate in work on or under the contract.

The applicant agrees that it will assist and cooperate actively with the administering agency and the Secretary of Labor in obtaining the compliance of contractors and subcontractors with the equal opportunity clause and the rules, regulations, and relevant orders of the Secretary of Labor, that it will furnish the administering agency and the Secretary of Labor such information as they may require for the supervision of such compliance, and that it will otherwise assist the administering agency in the discharge of the agency's primary responsibility for securing compliance.

The applicant further agrees that it will refrain from entering into any contract or contract modification subject to Executive Order 11246 of September 24, 1965, with a contractor debarred from, or who has not demonstrated eligibility for, Government contracts and federally assisted construction contracts pursuant to the Executive Order and will carry out such sanctions and penalties for violation of the equal opportunity clause as may be imposed upon contractors and subcontractors by the administering agency or the Secretary of Labor pursuant to Part II, Subpart D of the Executive Order. In addition, the applicant agrees that if it fails or refuses to comply with these undertakings, the administering agency

may take any or all of the following actions: Cancel, terminate, or suspend in whole or in part this grant (contract, loan, insurance, guarantee); refrain from extending any further assistance to the applicant under the program with respect to which the failure or refund occurred until satisfactory assurance of future compliance has been received from such applicant; and refer the case to the Department of Justice for appropriate legal proceedings.

** Corrected to read "invoked". In the original text the word "involved" was printed in error.*

MINORITY AND WOMEN BUSINESS ENTERPRISE INCLUSION PROGRAM PLAN

The City of South Bend, Indiana has shown its commitment to addressing Minority and Women's Business Enterprise ("MWBE") participation in public contracting through the adoption of the City of South Bend Ordinance No. 10761-21. Persons, partnerships, corporations, associations, or joint ventures awarded a contract by the City of South Bend through its agencies, boards, or commissions shall not discriminate against any employee or applicant for employment in the performance of a City contract with respect to hire, tenure, terms, conditions, or privileges of employment, or any matter directly or indirectly related to employment because of race, sex, religion, color, national origin, ancestry, age or disability that does not affect that person's ability to perform work.

Minority and Women's Business Enterprises are described in the Ordinance. A list of MBEs and WBEs (both certified and non-certified) can be found on the Indiana Department of Administration website: <http://www.in.gov/idoa/>. Documentation shall be provided with the bid that states the MBEs and WBEs that will be contracted, the dollar amount of the work that will be performed by the MBEs and WBEs on the project and the percentage of the dollar amount as it relates to the total bid amount by using *Form MBE-1.0, MBE Utilization Plan*, and *Form WBE-1.0, WBE Utilization Plan*.

The City, its agencies, boards, or commissions requires the Contractor's good faith efforts to obtain participation by those Contractors classified as MBEs and WBEs.

Failure to either meet the MBE and WBE goals or to provide evidence of good faith efforts for the bid will be grounds for rejecting a bid as non-responsive.

Bidders shall demonstrate good faith efforts to have active participation from MWBEs on this Project and supply written documentation evidencing such efforts by using *Forms MBE-2.0, Evidence of Good Faith Efforts and WBE-2.0, Evidence of Good Faith Efforts and Forms MBE-2.1, MBE Contacted and WBE-2.1, WBE Contacted*. Such documentation shall include, but is not limited to, the following items:

- a. A listing of all M/WBEs contacted including: (1) the name and address of the M/WBE; (2) the date of contact; (3) the type of contact (i.e., phone call, written solicitation, etc.); (4) the nature or type services or goods requested; and (5) the result of the contact.
- b. Written evidence of outreach and copies of email exchanges inviting and receiving bids, quotes or other responses from M/WBEs or other documentation of efforts to encourage and secure competitive responses from M/WBE and local businesses to be included in the benefits of building this Project.
- c. Written documentation of letters of introduction, invitations to forging majority/minority strategic alliances for capacity building, including but not limited to, mentoring, extensions of assistance on payroll, insurance, bonding, line of credit, technical skills or business skills.
- d. From time to time, projects will undergo a scope change prior to completion. This scope change will inevitably impact the Contractor's usage of MWBE's and the originally submitted Utilization Plan. It is the request of the City that when a project scope change occurs, the applicable Contractor shall utilize its best efforts to contract with M and W Subcontractors in a proportional manner as required by the scope change.

All bidders are actively encouraged to reach out to the M/WBEs in St. Joseph County, Indiana, other Indiana counties, and Berrien County, Michigan to utilize a good faith effort to forge constructive and lasting business partnerships.

Notwithstanding the foregoing, the award and performance of all City contracts shall comply with applicable federal, state, and local laws.

The City reserves the right to request verification of goal implementation throughout the course of the project.

If a goal exists, the winning respondent is contractually obligated to utilize the M/WBE's firms in a manner consistent with what was represented in its quote submission to the City. Deviations to the utilization plan must be requested in writing and approved by the City. The City reserves the right to initiate a change order in the amount equal to the difference in any subcontractor utilization if the utilization plan change is not approved.

CITY OF SOUTH BEND'S GUIDELINES FOR GOOD FAITH EFFORTS BY CONTRACTORS IN MEETING MWBE CONTRACT GOALS

Under the City of South Bend's Minority and Women's Business Enterprise (MWBE) Inclusion Program Plan (COSB Inclusion Plan), the City of South Bend (the City) is authorized to set "contract specific" goals to increase MWBE participation in City contracts and procurements.

MWBE participation goals are set based on availability of MWBE contractors within the City's geographic market area identified in the City's Disparity Study.

For contractors bidding on a construction, services, supplies or equipment contract where goals have been set for all or parts of the project, below is information relevant to "good faith efforts" to meet the contract goal.

When the City sets a contract goal, that means MWBE's are in fact available to perform work on the contract. **Project bidders must try diligently to meet the goal. Failure to make a good faith effort may result in rejection of your bid as non-responsive to the contract.**

Good faith efforts means actions undertaken by a contractor to achieve a contract goal which, by their scope, intensity, and appropriateness to the objective, can be reasonably expected to fulfill the Program's goals (City's Inclusion Plan, Section 4.B., No. 21).

A good faith effort is fully reviewable by the City. **Where a contract goal is not met, contractors must provide as much information as possible to help the City assess the contractor's good faith efforts to achieve the goal. Inadequate proof of good faith efforts may result in a finding that the contractor was non-responsive, causing its bid to be rejected even if it is the lowest.**

Good faith efforts require **active, aggressive efforts** by the prime contractor to obtain the contract MWBE participation goal. Mere pro forma efforts are not good faith efforts. To satisfy the good faith efforts test:

- A prime contractor may not reject a MWBE's bid solely because it is not the lowest bid received from subcontractors. If the MWBE's costs are reasonable and not excessive, the MWBE's quote or bid presumptively should be accepted on a contract requiring goals even if the MWBE's bid is not the lowest one received. However, if an MWBE's bid or quote is unreasonable or excessive, the prime contractor may reject the bid on that basis. The contractor has the burden of demonstrating the excessiveness or unreasonableness of the MWBE's bid or quote. Because the City must determine whether a MWBE quote was unreasonable or excessive, **Contractors must provide the City with copies of each MWBE and non MWBE quote submitted to the bidder when a non-MWBE was selected over an MWBE.**
- A contractor may not reject a MWBE as being unqualified without sound reasons based on a thorough investigation of the MWBE's capabilities. If a prime contractor rejects a MWBE as unqualified, the Contractor must provide the City with good reasons for this. The MWBE's industry standing or membership in a specific group, organization, political or social affiliation (example: union v. non-union) is not a basis to reject the MWBE for lack of qualification.
- The ability or desire of a prime contractor to perform the work of the contract with its own organization team does not relieve the prime contractor of the need to make good faith efforts to use MWBE sub contractors to meet the contract goal.

EXAMPLE: Total Project Estimate is \$500,000. An MWBE goal of 10% is set for a specific part of the project, i.e., \$50,000. Only one MWBE submits a quote to the prime contractor, and it is \$50,000. A non MWBE submits a quote of \$45,000. Rejecting the MWBE bid may not meet the requirement of making a good faith effort to meet the contract goal because: 1) the MWBE quote is within the goal percentage and dollar amount set for MWBE participation on the project; 2) selection of the MWBE quote guarantees that the contractor meets the set goal and that its bid will be deemed responsive; and 3) the difference between the MWBE and non MWBE quotes is not significant in terms of the overall contract amount (i.e., 1% of total contract).

If the MWBE's quote is \$53,000 and the non-MWBE bid is \$50,000, it may yet not be demonstrative of a good faith effort to reject the MWBE solely because the MWBE's quote is not the lowest. The excess is not greatly significant to the total contract cost, and it could reasonably be expected to be made up elsewhere in the contract while guaranteeing full goal compliance.

The above examples are illustrative only. The City will make a fair and reasonable judgment as to good faith efforts based on all information and documentation provided by bidders and taking into account the Quality, Quantity, and Intensity of the efforts made by a contractor to meet the contract goal.

GOOD FAITH EFFORTS MATERIALS TO BE INCLUDED WITH BID

If a contractor's bid does not meet the goal set for the contract, **the contractor must submit evidence of good faith efforts with its bid** so the City can determine whether the contractor is a responsive bidder. If the contractor's bid meets the MWBE goal, evidence of good faith effort is not required, but it would be prudent to include some evidence in case an error was made. The information required of a contractor who has not achieved the contract goal to show good faith efforts can be found in the South Bend Inclusion Program Plan at Section 8.B.3.d. as follows:

(b) Where the bidder cannot achieve the contract goal, the bidder must provide proof of having made good faith efforts to meet the goal. In making this determination of whether to issue a goal waiver, the City will consider, at a minimum, the bidder's efforts to:

(1) Solicit through all reasonable and available means (e.g., attendance at pre-bid meetings, advertising and written notices) the interest of all MWBEs in the scopes of work of the contract. The contractor shall provide interested MWBEs with timely, adequate information about the plans, specifications, and requirements of the contract to allow such firms to respond to the solicitation. The bidder must follow up initial solicitations with interested MWBEs.

(2) Select portions of the work to be performed by MWBEs in order to increase the likelihood that the contract goal will be achieved. This includes, where appropriate, breaking out contract work items into economically feasible units to facilitate participation, even when the bidder would otherwise prefer to perform these work items with its own forces. It is the bidder's responsibility to make a portion of the work available to MWBEs and to select those portions of the work or material needs consistent with the availability of such firms to facilitate their participation.

(3) Negotiate in good faith with interested MWBEs. Evidence of such negotiation includes the names, addresses, and telephone numbers of firms that were contacted; a description of the information provided regarding the plans and specifications for the work selected for subcontracting; and why agreements could not be reached. The bidder may not reject MWBEs as being unqualified without sound reasons based on a thorough investigation of their capabilities. That there may be some additional costs involved in finding and using MWBEs is not in itself sufficient reason for a bidder's failure to meet the contract goal, as long as such costs are reasonable. The ability or desire of a bidder to perform the work of a Contract with its own organization does not relieve it of the responsibility to make good faith efforts on all scopes of work within which subcontracting opportunities are available.

(4) Make efforts to assist interested MWBEs in obtaining bonding, lines of credit, or insurance as required by the City or the bidder, where appropriate.

(5) Make efforts to assist interested MWBEs in obtaining necessary equipment, supplies, materials, or related assistance or services, where appropriate.

Materials that should be submitted to support a contractor's good faith efforts include:

- Copies of advertisements, notices, or solicitations from contractor to MWBE's-- to include date and time of issuance;
- A list of all locations where advertisements or notices to MWBE's were placed or solicitations sent;
- Copies of communication between contractor and MWBE's in response to contractor's advertisements, notices, or solicitations;
- Proof of contractor's break-out of contract items into units feasible for performance by WMBE's;
- Proof of communications between the contractor and MWBE regarding negotiations for agreements, and why agreement could not be reached, as stated more specifically in above Subsection (b) (3);
- Proof of bids or quotes from MWBE's and those from non MWBE's when non MWBE's bid or quote is used;
- Proof of efforts made by contractor to assist MWBE to participate in contract, where appropriate; and
- Any other information tending to show that Contractor made active, aggressive efforts to meet the MWBE participation goal but despite good faith efforts was unable to do so.

CITY OF SOUTH BEND, INDIANA
CONTRACTOR'S BID FOR PUBLIC WORK
M/WBE CHECKLIST

Project Name PW Service Center Salt Dome Roof Replacement
Project No. R126-021
For Bids Due 9am EDT – June 9th, 2026 to bpwbids@southbendin.gov
Contractor Name: _____

The City seeks to promote equal opportunity for minority and women-owned businesses, including small local businesses, and to encourage utilization of such businesses in City contracting and procurement.
THIS FORM MUST BE SUBMITTED WITH YOUR BID IF THE BID IS AT OR ABOVE \$150,000.

****THIS FORM ONLY APPLIES TO QUOTES GREATER THAN \$150,000. ****

It is the sole responsibility of the potential bidder to comply with all submission requirements applicable to the bidder in Section 14.5 of the City of South Bend, Indiana Code of Ordinances and the Minority and Women Business Program Plan.

INSTRUCTIONS:

If you intend to comply with the stipulated MBE and WBE participation goals, complete Section I only. If you are unwilling to affirm in writing your intent to comply with the stipulated MBE and WBE participation goals and wish to propose adjusted goals, complete Section II and complete forms MBE-2.0, WBE-2.0, MBE-2.1, and WBE-2.1.

I. M/WBE CHECKLIST FOR INTENT TO MEET STIPULATED MBE AND WBE PARTICIPATION

- a) By checking this box, I hereby acknowledge that the City reserves the right to request supplemental information, additional verification of any information provided by me.
- b) By checking this box, I hereby acknowledge that I will meet or exceed the stipulated MBE and WBE participation goals of this contract.
- c) By checking this box, I agree to comply with all tracking and reporting, including online tracking software for M/WBE participation.
- d) By checking this box, I understand that a failure to meet the contractual obligations for M/WBE participation shall be a breach of contract. I understand that the City shall impose a penalty against the Contractor in the amount of the difference between the stipulated MBE and WBE goals and the actual amount paid to MBE and WBE subcontractors.

II. M/WBE CHECKLIST FOR GOOD FAITH EFFORTS PARTICIPATION GOAL ADJUSTMENT

- a) By checking this box, I hereby acknowledge that the City reserves the right to request supplemental information or additional verification of any information provided by me.
- b) By checking this box, I affirm I have made good faith efforts to seek opportunities to meet the stipulated MBE and WBE participation goals. I affirm I have made reasonable efforts (e.g., attendance at pre-bid meetings, advertising, and written notices) to solicit M/WBEs in the scopes of work of the contract.
 - i. I have completed the Evidence of Good Faith Efforts Forms [MBE-2.0 and WBE-2.0] and M/WBE Contacted Forms [MBE-2.1 and WBE-2.1] and submit these forms as part of my bid.
 - ii. Based on my Good Faith Efforts, I affirm that I will meet or exceed the following adjusted utilization percentages as a commitment of this contract in lieu of the stipulated goals:
_____ % MBE _____ % WBE
- c) Adjusted goals should be somewhere between 0% and the stipulated goal percentage. By checking this box, I understand that a failure to meet the contractual obligations for M/WBE participation shall be a breach of contract. I understand that the City shall impose a penalty against the Contractor in the amount of the difference between the adjusted utilization percentages and the actual amount paid to MBE and WBE subcontractors.
- d) By checking this box, I hereby acknowledge that the determination of whether a bidder has made good faith efforts and should be granted a goal adjustment will be made by the M/WBE Program Administrator, in consultation with the City's Legal Department and Department of Public Works.
- e) By checking this box, I agree to comply with all tracking and reporting, including online tracking software for M/WBE participation, even if a goal adjustment is granted.

Date: 6-8-2026

Signed by:

(Sign Here) 22256710EE094A8...

Tyler Batty
(Print Name Here)

Alice Homes LLC
(Name of Company)

12900 Coldwater Drive
(Address of Company)

Evansville
(City)

Indiana
(State)

812-480-7021
(Telephone Number)

alien. Contractor agrees that he/she/it shall enroll in and verify the work eligibility status of all of Contractor's newly hired employees through the E-Verify Program as defined by I.C. 22-5-1.7-3. Contractor's documentation of enrollment and participation in the E-Verify Program is included and attached as part of this bid/quote; and

5. Contractor shall require his/her/its subcontractors performing work under this public contract to certify that the subcontractors do not knowingly employ or contract with an unauthorized alien, nor retain any employee or contract with a person that the subcontractor subsequently learns is an unauthorized alien, and that the subcontractor has enrolled in and is participating in the E-Verify Program. The Contractor agrees to maintain this certification throughout the term of the contract with the City of South Bend, and understands that the City may terminate the contract for default if the Contractor fails to cure a breach of this provision no later than thirty (30) days after being notified by the City.

6. Persons, firms, partnerships, corporations, associations, or joint venturers awarded a contract by the City of South Bend through its agencies, boards, or commissions shall not discriminate against any employee or applicant for employment in the performance of a City contract with respect to hire, tenure, terms, conditions, or privileges of contract or employment, or any matter directly or indirectly related to contracting or employment because of race, sex, religion, color, national origin, ancestry, gender expression, gender identity, sexual orientation, or due to age or disability that does not affect that person's ability to perform the work.

In awarding contracts for the purchase of work, labor, services, supplies, equipment, materials, or any combination of the foregoing including, but not limited to, public works contracts awarded under public bidding laws or other contracts in which public bids are not required by law, the City, its agencies, boards, or commissions will consider the Contractor's good faith efforts to obtain participation by those subcontractors certified by the State of Indiana as a Minority Business ("MBE") or as a Women's Business Enterprise ("WBE") as a factor in determining the lowest, responsible, responsive bidder.

Contractors seeking the award of a City contract cannot be required to award a subcontract to an MWBE; however, they may not unlawfully discriminate against said MBE/WBE. On goal-eligible contracts, Contractors are required to either meet both MBE and WBE utilization goals or demonstrate that the Contractor has made good faith efforts to obtain participation from MBE and WBE subcontractors. A finding of noncompliance or a discriminatory practice shall prohibit that Contractor from being awarded a City contract for a period of one (1) year from the date of such determination, and such determination may also be grounds for terminating the contract to which the discriminatory practice or noncompliance pertains.

7. The undersigned Contractor agrees that the following nondiscrimination commitment shall be made a part of any contract which it may henceforth enter into with the City of South Bend, Indiana or any of its agencies, boards or commissions.

Contractor agrees not to discriminate against or intimidate any employee or applicant for employment in the performance of this contract with privileges of employment, or any matter directly or indirectly related to employment, because of race, religion, color, sex, gender expression, gender identity, sexual orientation, handicap, national origin or ancestry. Breach of this provision may be regarded as material breach of contract.

I, the undersigned bidder or agent as contractor on a public works project, understand my statutory obligations to the use of steel products or foundry products made in the United States (I.C. 5-16-8-1). I hereby certify that I and all subcontractors employed by me for this project will use steel products or foundry products made in the United States on this project if awarded. I understand I have an affirmative duty to notify the City in my bid that my proposal does not include the use of steel products or foundry products made in the United States. I understand it is my sole obligation and responsibility to provide a justification to the City, subject to review and approval, why the cost of United States made steel or foundry products is unreasonable. Prior to award and upon submission of bid which does not use steel products or foundry products made in the United States, the City, through its director of public works, shall make a determination if the price of United States made steel or foundry is unreasonable. I understand that violations hereunder may result in forfeiture of contractual payments.

I hereby affirm under the penalties of perjury that the facts and information contained in the foregoing bid for public works are true and correct.

Dated this 8th day of June, 2026

Alice Homes LLC

Contractor/Bidder (Firm)

Signed by:



Signature of Contractor/Bidder or Its Agent

Tyler Batty - Owner

Printed Name and Title

Subscribed and sworn to before me this _____ day of _____, 20____

My Commission Expires _____

Notary Public

County of Residence _____



QUOTE/PROPOSAL CITY OF SOUTH BEND

PROJECT NAME PW Service Center Salt Dome Roof Replacement

PROJECT NO. R126-021

QUOTES DUE 9am EDT – June 9th, 2026 to bpwbids@southbendin.gov

Item No.	Description	Quantity	Unit	Unit Price	Total Amount
1	Salt Dome Roof Replacement including all trades.	1	LS	249,658.62	\$ 249,658.62
Total Amount of Quote					\$ 249,658.62

Firm: Alice Homes LLC

Address: 12900 Coldwater Drive

City/State/Zip: Evansville, IN 47725 Telephone Number: () 812-480-7021

Fax Number: ()

Signed by:
By 
22256710EE094A8... (Signature)

Tyler Batty
(Printed Name of Person Signing)

**CITY OF SOUTH BEND
MINORITY AND WOMEN BUSINESS ENTERPRISE INCLUSION PROGRAM PLAN**



**FORM MBE-2.0
EVIDENCE OF GOOD FAITH EFFORTS**

If you are unwilling to affirm in writing your intent to comply with the stipulated MBE participation goals and wish to propose adjusted goals, complete this form and Section II of the M/WBE Checklist.

PW Service Center Salt Dome Roof

Project Number: Replacement Date: _____

Project Name: R126-021

Bidder: _____

Contact Person: _____ Telephone: _____

Address: _____

City: _____ State: _____ Zip: _____

Email: _____

To determine whether a bidder has demonstrated good faith efforts to reach the MBE utilization goal set forth in the City of South Bend Public Works Project Specifications, the City and its agencies, boards, or commissions, **REQUIRE ALL** of the following Good Faith Efforts as listed in the table below*:

	EVIDENCE OF GOOD FAITH EFFORTS
	MBE LIST(S): The bidder reviewed 1) the City of South Bend's Minority and Women Business Enterprise Inclusion Program Plan; 2) the list of certified MWBEs provided by the City; and 3) the Indiana Department of Administration list of Minority and Women Owned Businesses (both certified and non-certified) found at: http://www.in.gov/idoa/ .
	GOOD FAITH EFFORTS TO OBTAIN MBE PARTICIPATION
	The bidder shall initial each item below, as evidence of its good faith efforts to obtain MBE participation in the awarded contract.
	I affirm that I reviewed the City of South Bend's Minority and Women Business Enterprise Inclusion Program Plan and the Indiana Department of Administration's certified list of Indiana Minority and Women Business Enterprises, found on their website (http://www.in.gov/idoa/).
	I affirm that I have made good faith efforts to select portions of the contract work to be performed by MBEs, including, where appropriate, breaking out contract work items into economically feasible units to facilitate MBE participation.
	I affirm that I have made good faith efforts to solicit through all reasonable and available means the interest of all MBEs in the scopes of work of the contract.
	I affirm that I attended all pre-bid meetings scheduled by the City of South Bend to inform MBEs of contracting and subcontracting opportunities.
	I affirm that I advertised in general circulation and/or trade association publications concerning subcontract opportunities and allowed MBEs reasonable time to respond to such advertisements.
	I affirm that I performed any and all necessary steps to provide written notices in a manner reasonably calculated to inform MBEs of subcontracting opportunities and allowed sufficient time for MWBEs to participate effectively.
	I affirm that I followed up on initial solicitations with interested MBEs.
	I affirm that I negotiated with interested MBEs in good faith, including providing such MBEs with adequate information about the plans, specifications and other requirements of the subcontract.
	I affirm that I have made good faith efforts to assist interested MBEs in obtaining bonding, lines of credit, or insurance as required by the City or the bidder, where appropriate.

**CITY OF SOUTH BEND
MINORITY AND WOMEN BUSINESS ENTERPRISE INCLUSION PROGRAM PLAN**



**FORM MBE-2.0
EVIDENCE OF GOOD FAITH EFFORTS**

		I affirm that I have made good faith efforts to assist interested MBEs in obtaining necessary equipment, supplies, materials, or related assistances or services, where appropriate.
		I affirm that I did not reject any MBEs as unqualified without sound business reasons based on a thorough investigation of their capabilities.
	<p>CONTRACT RECORDS: The bidder has maintained the following records for each MBE that has bid on the subcontracting opportunity:</p> <ol style="list-style-type: none"> 1. Name, address, and telephone number; 2. A description of information provided by the bidder or subcontractor; and 3. A statement of whether an agreement was reached, and if not, why not, including any reasons for concluding that the MBE was unqualified to perform the job. 	

***Proper demonstration of Good Faith Efforts requires your initials next to all of the above boxes. Any omissions shall be considered grounds for rejection of the bid by the Board of Public Works. The City of South Bend reserves the right to request additional information.**

**CITY OF SOUTH BEND
MINORITY AND WOMEN BUSINESS ENTERPRISE INCLUSION PROGRAM PLAN**



**FORM WBE-2.0
EVIDENCE OF GOOD FAITH EFFORTS**

If you are unwilling to affirm in writing your intent to comply with the stipulated WBE participation goals and wish to propose adjusted goals, complete this form and Section II of the M/WBE Checklist.

PW Service Center Salt Dome Roof

Project Number: Replacement Date: _____

Project Name: R126-021

Bidder: _____

Contact Person: _____ Telephone: _____

Address: _____

City: _____ State: _____ Zip: _____

Email: _____

To determine whether a bidder has demonstrated good faith efforts to reach the WBE utilization goals set forth in the City of South Bend Public Works Project Specifications, the City and its agencies, boards, or commissions, **REQUIRE ALL** of the following Good Faith Efforts as listed in the table below*:

	EVIDENCE OF GOOD FAITH EFFORTS
	WBE LIST(S): The bidder reviewed 1) the City of South Bend's Minority and Women Business Enterprise Inclusion Program Plan; 2) the list of certified MWBEs provided by the City; and 3) the Indiana Department of Administration list of Minority and Women Owned Businesses (both certified and non-certified) found at: http://www.in.gov/idoa/ .
	GOOD FAITH EFFORTS TO OBTAIN WBE PARTICIPATION
	The bidder shall initial each item below, as evidence of its good faith efforts to obtain WBE participation in the awarded contract.
	I affirm that I reviewed the City of South Bend's Minority and Women Business Enterprise Inclusion Program Plan and the Indiana Department of Administration's certified list of Indiana Minority and Women Business Enterprises, found on their website (http://www.in.gov/idoa/).
	I affirm that I have made good faith efforts to select portions of the contract work to be performed by WBEs, including, where appropriate, breaking out contract work items into economically feasible units to facilitate MWBE participation.
	I affirm that I have made good faith efforts to solicit through all reasonable and available means the interest of all WBEs in the scopes of work of the contract.
	I affirm that I attended all pre-bid meetings scheduled by the City of South Bend to inform WBEs of contracting and subcontracting opportunities.
	I affirm that I advertised in general circulation and/or trade association publications concerning subcontract opportunities and allowed WBEs reasonable time to respond to such advertisements.
	I affirm that I performed any and all necessary steps to provide written notices in a manner reasonably calculated to inform WBEs of subcontracting opportunities and allowed sufficient time for WBEs to participate effectively.
	I affirm that I followed up on initial solicitations with interested WBEs.
	I affirm that I negotiated with interested WBEs in good faith, including providing such WBEs with adequate information about the plans, specifications and other requirements of the subcontract.

**CITY OF SOUTH BEND
MINORITY AND WOMEN BUSINESS ENTERPRISE INCLUSION PROGRAM PLAN**



**FORM WBE-2.0
EVIDENCE OF GOOD FAITH EFFORTS**

	<p>I affirm that I have made good faith efforts to assist interested WBEs in obtaining bonding, lines of credit, or insurance as required by the City or the bidder, where appropriate.</p>
	<p>I affirm that I have made good faith efforts to assist interested WBEs in obtaining necessary equipment, supplies, materials, or related assistances or services, where appropriate.</p>
	<p>I affirm that I did not reject any WBEs as unqualified without sound business reasons based on a thorough investigation of their capabilities.</p>
	<p>CONTRACT RECORDS: The bidder has maintained the following records for each WBE that has bid on the subcontracting opportunity:</p> <ol style="list-style-type: none"> 1. Name, address, and telephone number; 2. A description of information provided by the bidder or subcontractor; and 3. A statement of whether an agreement was reached, and if not, why not, including any reasons for concluding that the WBE was unqualified to perform the job.

***Proper demonstration of Good Faith Efforts requires your initials next to all of the above boxes. Any omissions shall be considered grounds for rejection of the bid by the Board of Public Works. The City of South Bend reserves the right to request additional information.**

CITY OF SOUTH BEND
MINORITY AND WOMEN BUSINESS ENTERPRISE INCLUSION PROGRAM PLAN



FORM MBE-2.1
MBE CONTACTED

This completed form should be supplied with Bids that pertain to City of South Bend Public Works Projects requiring Good Faith Efforts to contact MBEs. It is the bidder's sole responsibility to verify whether any listed minority or woman business meets the MBE qualifications. Attach additional pages if necessary.

PAGE _____ OF _____

Project Number: PW Service Center Salt Dome
Roof Replacement MBE Participation Goal _____

Project Name: R126-021

Bidder: _____

By: _____
(Signature) (Title) (Date)

MBE Firm _____

Owner or Contact at MBE Firm _____

Telephone: _____ Fax: _____ Email: _____

TYPE OF WORK SOLICITED FOR THIS PROJECT:

RESULTS OF CONTACT WITH THE MBE FIRM:

MBE Firm _____

Owner or Contact at MBE Firm _____

Telephone: _____ Fax: _____ Email: _____

TYPE OF WORK SOLICITED FOR THIS PROJECT:

RESULTS OF CONTACT WITH THE MBE FIRM:

CITY OF SOUTH BEND
MINORITY AND WOMEN BUSINESS ENTERPRISE INCLUSION PROGRAM PLAN



FORM WBE-2.1
WBE CONTACTED

This completed form should be supplied with Bids that pertain to City of South Bend Public Works Projects requiring Good Faith Efforts to contact WBEs. It is the bidder's sole responsibility to verify whether any listed minority or woman business meets the WBE qualifications. Attach additional pages if necessary.

PAGE _____ OF _____

Project Number: PW Service Center Salt Dome
Roof Replacement WBE Participation Goal _____

Project Name: R126-021

Bidder: _____

By: _____
(Signature) (Title) (Date)

WBE Firm _____

Owner or Contact at WBE Firm _____

Telephone: _____ Fax: _____ Email: _____

TYPE OF WORK SOLICITED FOR THIS PROJECT:

RESULTS OF CONTACT WITH THE WBE FIRM:

WBE Firm _____

Owner or Contact at WBE Firm _____

Telephone: _____ Fax: _____ Email: _____

TYPE OF WORK SOLICITED FOR THIS PROJECT:

RESULTS OF CONTACT WITH THE WBE FIRM:

215 S. DR. MARTIN LUTHER
KING JR., BLVD, SUITE 400
SOUTH BEND, INDIANA 46601



PHONE 574/ 235-9251
FAX 574/ 235-9171
TDD 574/ 235-5567

CITY OF SOUTH BEND JAMES MUELLER, MAYOR
BOARD OF PUBLIC WORKS

Date: June 3, 2026
To: All Planholders
From: Lidya Abreha, Project Engineer
Subject: Addendum Number: 1
Project Name: PW Service Center Salt Dome Roof Replacement
Project No.: 126-026

ACKNOWLEDGEMENT OF RECEIPT OF ADDENDUM

Date Received: _____

This addendum is being forwarded to you for the above referenced project.

Please sign below and acknowledge receipt of this Addendum by faxing this sheet to the Board of Public Works at (574) 235-9171 within 48 hours of receipt. A copy MUST also be included with your bid package upon submittal.

THIS ADDENDUM MAY AFFECT YOUR BID.

Notes:

The attached documents are hereby added to the Specifications and Contract Documents and become a part of herein.

Company: Alice Homes LLC

Authorized Signature:  Signed by:
22256710EE094A8...

Date: 6-8-2026

**PW Service Center Salt Dome Replacement
R126-021
Addendum No. 1**

Date: June 3, 2026

To: All Planholders

From: Lidya Abreha, Project Engineer

You must acknowledge a receipt of this addendum by signing the first page and returning a copy with your bid.

The items in this addendum are to become part of the original documents as if included therein. Only the noted items are affected, and the remainder of the original contract document is to remain in its entirety.

This Addendum modifies the Contract Documents as follows:

PART 1 – CONTRACTOR QUESTIONS

1.01 Question 1. Is there any indication of size and dimensions? How many squares is it? How steep is the roof pitch? **Please see attached original as-built drawing for the Salt Dome.**

1.02 Question 2. What types of shingles do you want installed? What color is preferred?

Architectural shingles

Color range: **Black to dark charcoal or approved equivalent.**

This addendum consists of a total 3 pages

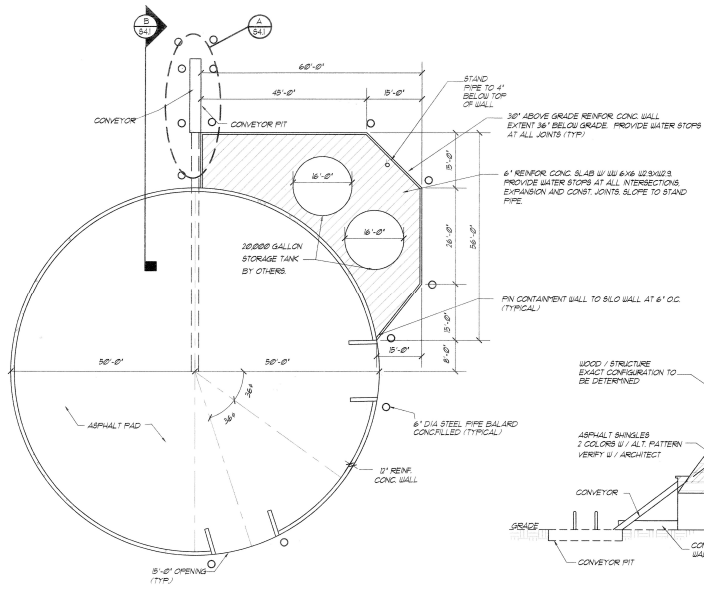

SALT BARN-PLAN

SCALE: 1/16" = 1'-0"

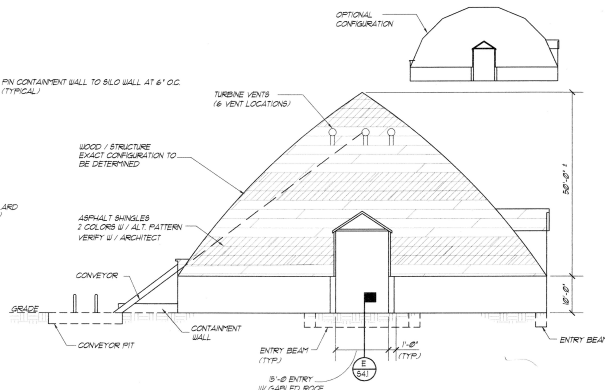

SALT SILO ELEVATION-SOUTH

SCALE: 1/16" = 1'-0"

NOTES:
 1. REFER TO SHEET S0 FOR GENERAL STRUCTURAL NOTES
 2. DETAILS SIZES AND LAYOUT SHOWN ARE FOR REFERENCE PURPOSES AND TO ESTABLISH MINIMUM STRUCTURAL REQUIREMENTS. ACTUAL CONSTRUCTION DETAILS, SIZES AND SPECIFIC MATERIALS SHALL BE SUBMITTED TO ARCHITECT BY MANUFACTURER IN ACCORDANCE WITH SPECIFICATION DIVISION 5 FOR REVIEW AND APPROVAL.

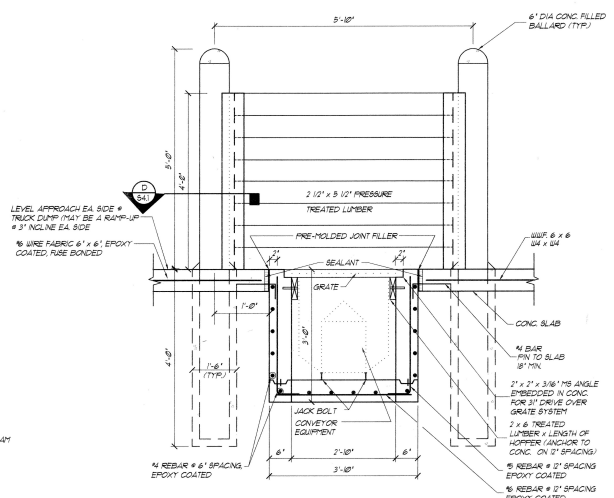

CONVEYOR PIT DETAIL

SCALE: 3/4" = 1'-0"

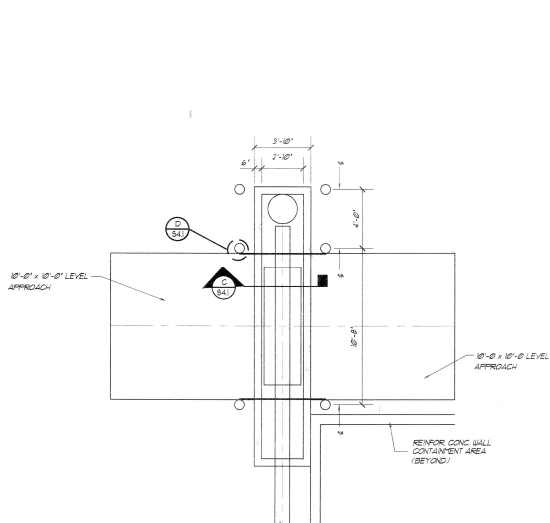

SECTION

SCALE: 1/4" = 1'-0"

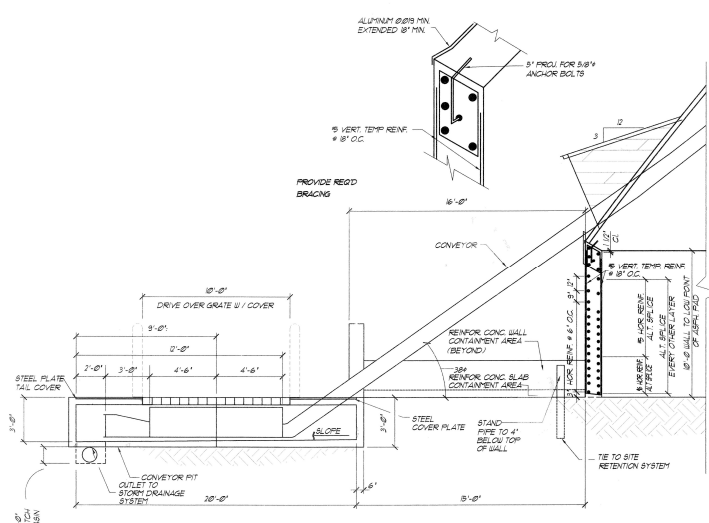

SECTION

SCALE: 1/4" = 1'-0"

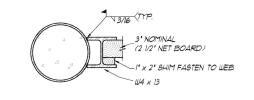

DETAIL

SCALE: 1/2" = 1'-0"



ENTRY BEAM DETAIL

SCALE: 3/4" = 1'-0"



AS BUILT DRAWINGS

REV.	DATE	DESCRIPTION

HERCEG ARCHITECTS SURVEYORS
KEN HERCEG & ASSOCIATES, INC.
 211 West Washington Street, Suite 3100, South Bend, Indiana 46601
 Phone: (317) 339-4500 Fax: (317) 339-9175 Email: ken@herceginc.com



SBDPW SERVICE CENTER
 DEPT. OF PUBLIC WORKS
 SOUTH BEND, INDIANA

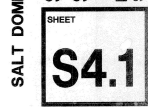

215 S. DR. MARTIN LUTHER
KING JR., BLVD, SUITE 400
SOUTH BEND, INDIANA 46601



PHONE 574/ 235-9251
FAX 574/ 235-9171
TDD 574/ 235-5567

CITY OF SOUTH BEND JAMES MUELLER, MAYOR
BOARD OF PUBLIC WORKS

Date: June 5, 2026
To: All Planholders
From: Lidya Abreha, Project Engineer
Subject: Addendum Number: 2
Project Name: PW Service Center Salt Dome Roof Replacement
Project No.: R126-021

ACKNOWLEDGEMENT OF RECEIPT OF ADDENDUM

Date Received: _____

This addendum is being forwarded to you for the above referenced project.

Please sign below and acknowledge receipt of this Addendum by faxing this sheet to the Board of Public Works at (574) 235-9171 within 48 hours of receipt. A copy MUST also be included with your bid package upon submittal.

THIS ADDENDUM MAY AFFECT YOUR BID.

Notes:

The attached documents are hereby added to the Specifications and Contract Documents and become a part of herein.

Company: Alice Homes LLC _____

Authorized Signature: _____

Signed by:

22256710EE094A8...

Date: 6-7-2026 _____

**PW Service Center Salt Dome Replacement
R126-021
Addendum No. 2**

Date: June 5, 2026

To: All Planholders

From: Lidya Abreha, Project Engineer

You must acknowledge a receipt of this addendum by signing the first page and returning a copy with your bid.

The items in this addendum are to become part of the original documents as if included therein. Only the noted items are affected, and the remainder of the original contract document is to remain in its entirety.

This Addendum modifies the Contract Documents as follows:

PART 1 – CONTRACTOR QUESTIONS

1.01 Question 1. What specific performance rating do you require for architectural shingles?
Class 3 impact rating and 130 MPH wind rating.

1.02 Question 2. How should we account for deteriorated or damaged decking in the quoting process?
Please see updated quote proposal form attached to this addendum.

PART 2 – SPECIAL PROVISIONS

2.01 Section **IX. PROSECUTION AND PROGRESS**

1. **REVISE B.1.** The project will have a completion date of **60 calendar days**. The contract time will start when the Notice to Proceed is delivered and signed.

PART 3 – CONTRACTOR’S BID FOR PUBLIC WORKS

3.01 **Revise Base Quote Pay Items** (Revised Quote Proposal Page attached)

Item No.	Description	Quantity	Unit	Unit Price	Total Amount
1	Salt Dome Roofing Removal and Replacement as stated in the specifications	1	LS	\$ 205.603.62	\$ 205.603.62
2	Replacement of deteriorated roof decking with 1/2" OSB	330	Sheet	\$ 133.50	\$ 44,055.00
Total Amount of Quote					\$ 249.658.62

This addendum consists of a total of 3 pages



QUOTE/PROPOSAL CITY OF SOUTH BEND

PROJECT NAME PW Service Center Salt Dome Roof Replacement

PROJECT NO. R126-021

QUOTES DUE 9am EDT – June 9th, 2026 to bpwbids@southbendin.gov

Item No.	Description	Quantity	Unit	Unit Price	Total Amount
1	Salt Dome Roofing Removal and Replacement as stated in the specifications	1	LS	\$ 205.603.62	\$ 205.603.62
2	Replacement of deteriorated roof decking with 1/2" OSB	330	Sheet	\$ 133.50	\$ 44,055.00
Total Amount of Quote					\$ 249.658.62

Firm: Alice Homes LLC

Address: 12900 Coldwater Drive

City/State/Zip: Evansville, IN 47725 Telephone Number: () 812-480-7021

Fax Number: ()

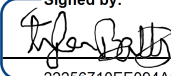
Signed by:
By 
22256710EE094A8... (Signature)

Tyler Batty
(Printed Name of Person Signing)