

33 PRESERVATION BRIEFS

The Preservation and Repair of Historic Stained and Leaded Glass

Neal A. Vogel and Rolf Achilles



National Park Service
U.S. Department of the Interior

Heritage Preservation Services

“Stained glass” can mean colored, painted or enameled glass, or glass tinted with true glass “stains.” In this Brief the term refers to both colored and painted glass. “Leaded glass” refers generically to all glass assemblies held in place by lead, copper, or zinc comes. Because the construction, protection, and repair techniques of leaded glass units are similar, whether the glass itself is colored or clear, “stained glass” and “leaded glass” are used interchangeably throughout the text.

Glass is a highly versatile medium. In its molten state, it can be spun, blown, rolled, cast in any shape, and given any color. Once cooled, it can be polished, beveled, chipped, etched, engraved, or painted. Of all the decorative effects possible with glass, however, none is more impressive than “stained glass.” Since the days of ancient Rome, stained glass in windows

and other building elements has shaped and colored light in infinite ways.

Stained and leaded glass can be found throughout America in a dazzling variety of colors, patterns, and textures (Fig. 1). It appears in windows, doors, ceilings, fanlights, sidelights, light fixtures, and other glazed features found in historic buildings (Fig. 2). It appears in all building types and architectural styles—embellishing the light in a great cathedral, or adding a touch of decoration to the smallest rowhouse or bungalow. A number of notable churches, large mansions, civic buildings, and other prominent buildings boast windows or ceilings by LaFarge, Tiffany, Connick, or one of many other, lesser-known, American masters, but stained or leaded glass also appears as a prominent feature in great numbers of modest houses built between the Civil War and the Great Depression.

This Brief gives a short history of stained and leaded glass in America. It also surveys basic preservation and documentation issues facing owners of buildings with leaded glass. It addresses common causes of deterioration and presents repair, restoration, and protection options. It does not offer detailed advice on specific work treatments. Glass is one of the most durable, yet fragile building materials. While stained glass windows can last for centuries, as the great cathedrals of Europe attest, they can be instantly destroyed by vandals or by careless workmen. Extreme care must therefore be exercised, even in the most minor work. For this reason, virtually all repair or restoration work undertaken on stained and leaded glass must be done by professionals, whether the feature is a magnificent stained glass window or a clear, leaded glass storefront transom. Before undertaking any repair work, building owners or project managers should screen studios carefully, check references, inspect other projects, and require duplicate documentation of any work so that full records can be maintained. Consultants should be employed on major projects.



Figure 1. This door and transom suggest the richness of 19th century leaded glass. Photo: Jack E. Boucher, HABS.

Historical Background

Glassblowers were among the founders of Jamestown in 1607, and early glass manufacturing was also attempted in 17th-century Boston and Philadelphia. Dutch colonists in the New Netherlands enjoyed painted oval or circular medallions that bore the family's coat of arms or illustrated Dutch proverbs. German colonists in the mid-Atlantic region also began early glass ventures. Despite the availability of good natural ingredients, each of these early American glassmakers eventually failed due to production and managerial difficulties. As a result, colonists imported most of their glass from England throughout the 17th and 18th centuries.

Social values as well as high costs also restricted the use of stained and other ornamental glass. This was particularly true with regard to churches. The Puritans, who settled New England, rejected the religious imagery of the Church of England, and built simple, unadorned churches with clear glass windows. Less than 1% of the Nation's stained and leaded glass predates 1700. Considering the enormous loss of 17th-, 18th-, and early 19th-century buildings, *any* window glass surviving

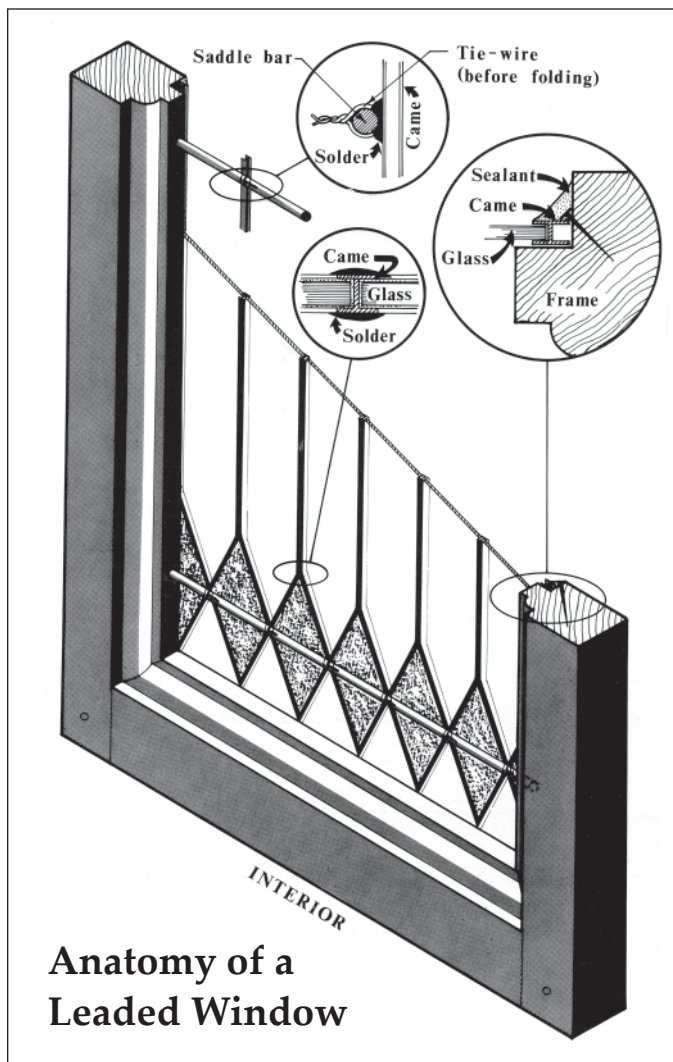

Figure 2. Components of a leaded glass window.



Figure 3. The entrance to the Morris-Jumel Mansion, New York City, is one of the earliest surviving installations of stained glass in the country. It features a fanlight and sidelights of large clear roundels and small bulls-eyes of red and orange glass tinted with silver stains from ca. 1810. Photo: Ken Moss.

from these periods is very significant (Fig. 3). Every effort should be made to document and preserve it.

Despite many failed starts, the War of 1812, and British competition, American glass production increased steadily throughout the 19th century. Stained glass was available on a very limited basis in America during the first quarter of the 19th century, but American stained glass did not really emerge in its own right until the 1840s. The windows at St. Ann and the Holy Trinity Episcopal Church in Brooklyn, New York, made by John and William Jay Bolton between 1843 and 1848, are perhaps the most significant early American stained glass installation (Fig. 4). Other important early stained glass commissions were the glass ceilings produced by the J. & G. H. Gibson Company of Philadelphia for the House and Senate chambers of the United States Capitol in 1859.

America's glass industry boomed during the second half of the 19th century. (And although stained and leaded glass is found nationwide, the manufacturing was based in the Northeast and Midwest, where good natural ingredients for glass, and coal reserves



Figure 4. *The windows at St. Ann and the Holy Trinity Episcopal Church, Brooklyn, New York, were made between 1843-1849 by John and William Jay Bolton. Photo: Leland A. Cook.*

for the kilns were available. Moreover, nearly all of the nationally renowned studios were based in major metropolitan areas of the central and northeastern states--near the manufacturers that supplied their raw materials.) In response to this growth, the industry formed self-regulating associations that established guidelines for business and production. In 1879 the Window Glass Association of America was established, and in 1903 The National Ornamental Glass Manufacturers' Association, precursor of the Stained Glass Association in America, was formed.

The 60 years from about 1870 to 1930 were the high point for stained glass in the U.S. In the early years, American stylistic demands reflected those current in Europe, including various historic revivals, and aesthetic and geometric patterns. American patterns prevailed thereafter; they tended to be more vivid, brash, and bold (Fig. 5).

After the 1893 Columbia World's Exposition, the Art Nouveau Style became the rage for windows. Sinuous nymphs, leggy maidens, whiplashed curves, lilies, and brambles became standard subjects until World War I. Among the leading proponents of the Art Nouveau Style were glassmakers John LaFarge and Louis Comfort Tiffany. Both men experimented independently throughout the 1870s to develop opalescent glass, which LaFarge was first to incorporate into his windows. Tiffany became the better-known, due in part to his prolific output.

He attracted world-class artists and innovative glassmakers to his studio. Today, "Tiffany" remains a household name. His favorite and most popular scenes were naturalistic images of flowers, colorful peacocks and cockatiels, and landscapes at sunrise and sunset (Fig. 6). LaFarge, while appreciated in his own day, gradually slid into relative obscurity, from which he has emerged in recent decades. Tiffany and LaFarge are the greatest names in American stained glass.

In dramatic contrast to the American Art Nouveau style was the Neo-Gothic movement that became so popular for church and university architecture across the country. Charles J. Connick was a leading designer of medieval-style windows characteristic of the style (Fig. 7).

Advocates of the Prairie Style, of whom Frank Lloyd Wright is the best known, rejected Tiffany's naturalistic scenes and Connick's Gothic imitations. (Fig. 8). Wright's rectilinear organic abstractions developed simultaneously with the similar aesthetic of the various European Secessionists. The creation of this style was aided by the development of zinc and copper comes in 1893. These comes—much stiffer than lead—made it possible to carry out the linear designs of Prairie School windows with fewer support bars. At first, these windows had only an elitist following, but they were soon widely accepted and proliferated during the early 20th century.

By 1900, stained and leaded glass was being mass-produced and was available to almost everyone. Leading home journals touted leaded glass windows for domestic use, and a nationwide building boom created an unprecedented demand for stained and leaded art glass windows, door panels, and transoms. Mail order catalogs from sash and blind companies appeared,

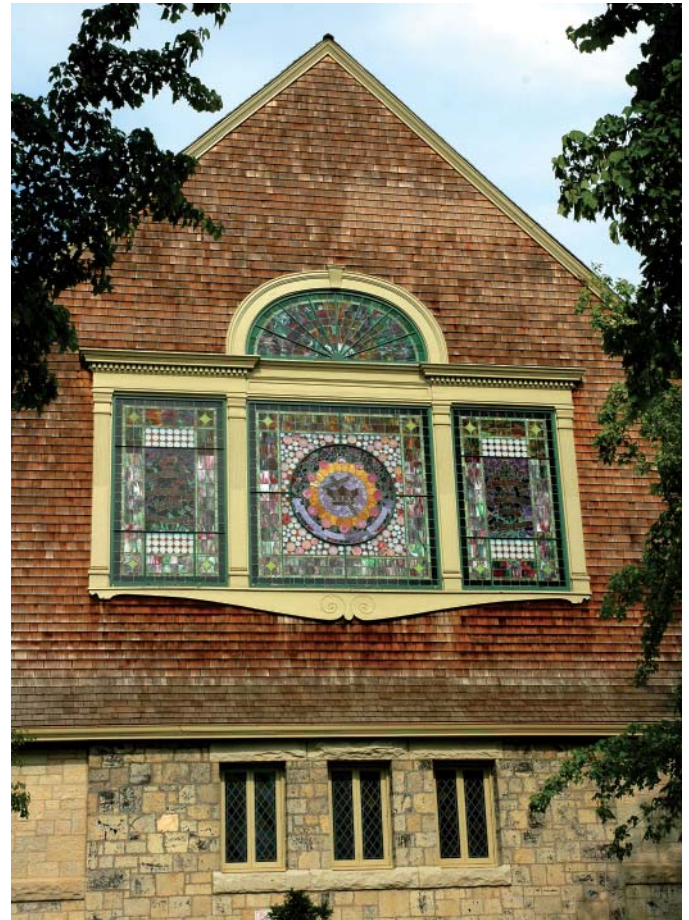

Figure 5. *Stained glass is an exterior feature as well as an interior one. As part of any preservation project, stained glass should be photographed from the exterior as well as the interior.*



Figure 6. This 1907 landscape window is typical of those produced by Tiffany Studios. Characteristics include the use of opalescent glass, intricate leading and organic copper foil work, acid-etching, plating (i.e., several layers of glass), and a sense of perspective.

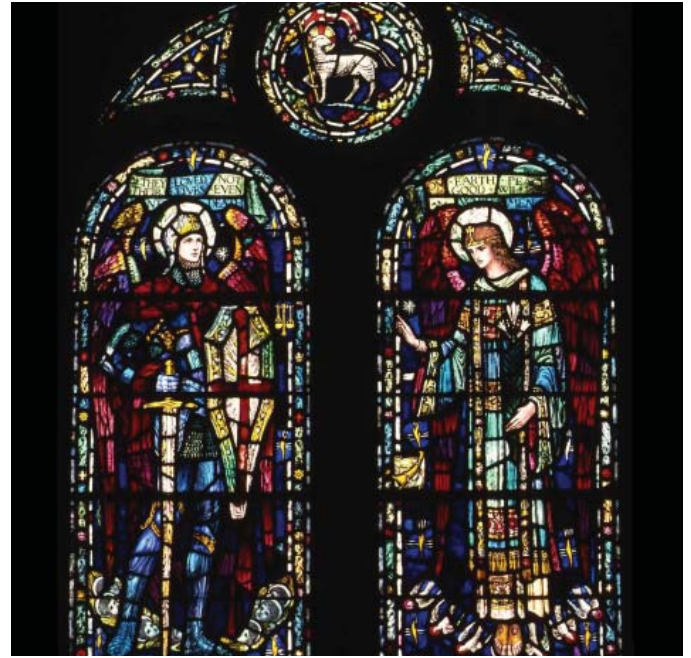

Figure 7. Charles J. Connick was another American master of stained glass. He worked in a modernized Neo-Gothic style. This window is from 1921. Photo: Diana Kincaid.



Figure 8. This 1902 window by Henry Webster Tomlinson reflects the Prairie School philosophy of providing ornamentation while retaining a view through the window.

some offering over 100 low-cost, mass produced designs (although the same catalogs assured buyers that their leaded glass was “made to order”) (Fig. 9).

The fading popularity of the ornate Victorian styles, combined with inferior materials used for mass production, essentially eliminated the production of quality leaded glass. The last mail order catalogs featuring stained glass were published in the mid-1920s, and tastes changed to the point that the 1926 *House Beautiful Building Annual* declared: “the crude stained glass windows in many of the Mansard-roof mansions of the ‘eighties [1880s] prove how dreadful glass can be when wrongly used.”

Some creative efforts expanded leaded glass media in new directions. Lead-overlay or “silhouette” glass was one novelty that climaxed in the late 1920s and early 1930s. Some designers sandwiched glass between layers of hand-cut sheet lead, while others sandwiched the perforated sheet lead between layers of glass. These windows present a playful reversal from traditional stained glass; in “silhouette” glass the lead metalwork, rather than the glass, becomes the primary art form (Fig. 10). However, such novelties failed to catch on during the Depression. World War II delivered the final blow and ornamental glass is seldom found in residential, commercial, and secular architecture after circa 1940. The great age of American stained glass was over. Fortunately, leaded glass panels survived in uncounted numbers throughout the country, and are now once again appreciated as virtually irreplaceable features of historic buildings.

Figure 9. A typical mail-order catalog page of art glass windows available in 1903 from the E. L. Roberts Company, Chicago.



Dating and Documenting Historic Leaded Glass

Before deciding on any treatment for historic leaded glass, every effort should be made to understand—and to record—its history and composition. Documentation is strongly encouraged for significant windows. Assigning an accurate date, maker, and style to a stained glass window often requires extensive research and professional help. A documentation and recording project, however, is worth the effort and expense, as insurance against accidents, vandalism, fire and other disasters. The better the information available, the better the restoration can be. The following sources offer some guidelines for dating leaded windows.

Building Context. The history of the building can provide ready clues to the history of its leaded windows, doors, and other elements. The construction date, and dates of major additions and alterations, should be ascertained. Later building campaigns may have been a time for reglazing. This is especially the case with churches and temples. They were often built with openings glazed with simple or generic clear leaded glass. Stained glass was added later as finances allowed. Conversely, the windows may be earlier than the building. They may have been removed from one structure and installed in another (once again, this is more likely with religious structures). Bills, inventories, and other written documents often give clues to the date and composition of leaded glass. Religious congregations, fraternal lodges, historical societies and other preservation organizations may have written histories that can aid a researcher.

Inscriptions and Signatures. Many studios and artists affixed signature plates to their work—often at the lower right hand corner. In the case of Tiffany windows, the signature evolved through several distinct phases, and helps date the piece within a few years: *Tiffany Glass Company* (1886-1892), *Tiffany Glass & Decorating Company* (with address, 1892-1902), *Tiffany Studios New York or Louis C. Tiffany* (post 1902). (Tiffany Studios, like others, did not always sign pieces and the absence of an inscription cannot be used to rule out a particular studio or artist.) Windows may also feature dated plaques commemorating a donor. However, these do not always indicate the date of the window, since windows were often installed before a donor was found. Nevertheless, such marks help establish a reasonable date range.

Composition and Other Stylistic Elements. These elements are more subjective, and call for a fairly broad knowledge of architecture and art history. Do the windows fit the general style of the building? The style of the window may reflect a stylistic period (e.g., Arts & Crafts, Art Nouveau, Prairie School).

The imagery or iconography of the windows may also reveal their overall historical context and establish a general time period.

Framing and Surround. Framing elements and the window surround can reveal information central to dating the window. Do moldings match other interior trim? Has the opening been altered? Is the window set in an iron frame (post-1850s), a steel frame (generally post-World War I), a cast stone or terra cotta frame (seen as early as the 1880s, but popular after 1900)?

Reinforcement and Leading Details. Does the window or other element have round bars or flat



Figure 10. This lead-silhouette stained glass face graces a 1928 coach house in Buffalo, and is attributed to D'Ascenzo Studios of Philadelphia.

The Importance of Context



Stained glass commissioned for a particular building was normally designed not only to reflect the shape of the opening but also to coordinate with other aspects of the overall setting such as the architectural style, adjacent materials, and interior decoration. The window opening, frame or sash colors, placement of the reinforcement, alignment with architectural elements, and orientation to natural light also establish the relationship between the stained glass and the building. The vibrant colors of opalescent glass, which can often be read from the exterior, and the linear designs of Prairie School windows, which often harmonize with both the interior and the exterior, are two examples that readily demonstrate the importance of architectural context to ornamental glass.

This important relationship between the glass and its setting, however, can be weakened or entirely lost over the years due to unsympathetic decorating schemes or building campaigns, damage, deterioration, inept repairs, or the mere accumulation of dirt.

Changes to the ornamentation and finish of the structural frame can have an especially pronounced effect on the overall appearance of a stained glass window or dome. In the Chicago Cultural Center dome the historic finishes of the ornamental cast iron frame have darkened considerably over the years, muting the dome's rich personality. In strong sunlight the glass is so dominant that the frame appears only as a silhouette. Restoring the vibrancy of the historic finish is necessary to recapture the equally important contribution of the frame to the original design intent of the dome. After careful investigation to document the historic appearance (right), a mock-up section of the frame was regilded with aluminum leaf (top). The dramatic effect of restoring the dome's overall context is readily apparent after only this small section of the frame was refinished.



bars? Flat bars began to appear about 1890; round bars, used since the Middle Ages, remained in use until the 1920s, when flat bars supplanted them. Comes can also give dating clues. Zinc comes, for example, developed by Chicago Metallic in association with Frank Lloyd Wright, first appeared in 1893. In general, however, dating a window by the came alone is difficult unless it is disassembled to view the "heart" (center web) for millmarks. Over one hundred varieties of lead came were available in the early 20th century. Moreover, came was sometimes produced to look old. Henderson's Antique Leading from the 1920s was made "to resemble the old hand wrought lead" and also carried "easy-fix" clip-on Georgian-style ornaments.

Glass. The glass itself can help in dating a window. Opalescent glass, for instance, was patented by John LaFarge in 1879. Tiffany patented two variations on LaFarge's technique in the same year. (Opalescent glass is translucent, with variegated colors resulting from internally refracted light. It features milky colored streaks.) Pre-1880 glass is usually smooth translucent colored glass (painted or not); glass with bold, deep colors is typical of the 1880s and 1890s, along with jewels, drapery glass and rippled glass. But such flamboyance faded out with the rest of Victoriana by about 1910. However, stained glass styles of the late 19th century continued to appear in ecclesiastical buildings after they passed from general fashion. Leaded beveled plate glass was popular in residential architecture after 1890, and was used profusely until the 1920s.

The level of documentation warranted depends upon the significance of the window, but it is very important to document repair and restoration projects before, during, and after project work. Photographs will normally suffice for most windows. For highly significant windows, rubbings as well as written documentation are recommended. The leading patterns in such windows are complex, particularly in plated windows (which have several layers). Rubbings are therefore encouraged for each layer when restored; they are invaluable if a disaster occurs and reconstruction is required. Annotated rubbings of the leadwork should be done with a wax stone on acid-free vellum.

To document windows properly, inscriptions should be recorded word for word, including misspellings, peculiarities in type style, and other details. Names and inscriptions in or on windows can indicate ethnic heritage, particularly in churches or civic structures where windows often reflect styles and themes from the congregation or community's origins. Lastly, any conjectural information should be clearly noted as such.



Figure 11. The face paint has failed substantially in the figure at the left. Ghost images of the feature are barely visible. Window (1903) by Edwin P. Sperry, glass by Tiffany Studios; “Old Main,” (1891-1893) Illinois Institute of Technology, Chicago. Photo: Rolf Achilles.

Deterioration of Stained and Leaded Glass

Three elements of leaded glass units are prone to damage and deterioration: the glass itself; the decorative elements (mostly applied paint); and the structural system supporting the glass.

Glass Deterioration

Glass is virtually immune to natural deterioration. Most American glass is quite stable—due to changes in glass composition made in the mid-19th century, particularly the increased silica content and the use of soda lime instead of potash as a source of alkali. Rarely, however, glass impurities or poor processing can cause problems, such as minor *discoloration* or tiny internal fractures (particularly in opalescent glass). And all glass can be darkened by dirt; this can often be removed. However, while glass does not normally deteriorate, it is susceptible to *scratching* or *etching* by abrasion or chemicals, and to *breakage*.

The greatest cause of breakage or fracture is physical impact. Leaded glass in doors, sidelights, and low windows is particularly susceptible to breakage from accidents or vandalism. When set in operable doors or windows, leaded glass can crack or weaken from excessive force, vibration, and eventually even from normal use. Cracks can also result from improperly set nails or points that hold the window in the frame, or more rarely, by structural movement within the building. Leaded glass that is improperly annealed can crack on its own from internal stress. (Annealing is

the process by which the heated glass is slowly cooled; the process is akin to tempering metal.) Glass can also disintegrate from chemical instability or the intense heat of a fire. Finally, windows assembled with long, narrow, angular pieces of glass are inherently prone to cracking. Often the cause of the cracks can be determined by the path they travel: cracks from impact typically radiate straight from the source. Stress cracks caused by heat or improper annealing will travel an irregular path and change direction sharply.

Deterioration of Painted Glass

Painted glass, typically associated with pictorial scenes and figures found in church windows, often presents serious preservation challenges. If fired improperly, or if poor quality mixtures were used, painted glass is especially vulnerable to weathering and condensation. Some studios were notorious for poorly fired paints (particularly those working with opalescent glass), while others had outstanding reputations for durable painted glass. Paints can be applied cold on the glass or fused in a kiln. Since they are produced from ground glass, enamels do not “fade,” as often suggested, but rather flake off in particles. Several steps in the painting process can produce fragile paint that is susceptible to flaking. If applied too thick, the paint may not fuse properly to the glass, leaving small bubbles on the surface. This condition, sometimes called “frying,” can also result from poor paint mixtures or retouching. Paint failure is more commonly caused by under firing (i.e., baking the glass either at too low a temperature or for too little time). Unfortunately, in American stained glass, the enamels used to simulate flesh tones were typically generated from several layers that were fired at too low a temperature. This means the most difficult features to replicate—faces, hands and feet—are often the first to flake away (Fig. 11).

Structural Deterioration

The greatest and the most common threat to leaded glass is deterioration of the skeletal structure that holds the glass. The structure consists of frame members, and lead or zinc (and occasionally brass or copper) came that secures individual pieces of glass. Frame members include wood sash and muntins that decay, steel t-bars and “saddle bars” that corrode, and terra cotta or stone tracery that can fracture and spall (Fig. 12). When frames fail, leaded glass sags and cracks due to insufficient bracing; it may even fall out from wind pressure or vibration.

Wood sash are nearly always used for residential windows and are common in many institutional windows as well. Left unprotected, wood and glazing compounds decay over time from moisture and exposure to sunlight—with or without protective storm glazing—allowing glass to fall out.



Figure 12. Stained glass frames are typically wood, steel or stone; however, other materials, and their inherent problems, can also be found as seen in this photograph of cracked terra cotta frames from 1926.

Steel frames and saddle bars (braces) corrode when not maintained, which accelerates the deterioration of the glazing compound and loosens the glass. Moreover, operable steel ventilators and windows are designed to tight tolerances. Neglect can lead to problems. Eventually, they either fail to close snugly or corrode completely shut. The leaded glass is then frequently reinstalled in aluminum window units, which require wider sections for equal strength and typically results in an inch or more of the glass border being trimmed. Instead of relocating glass in aluminum frames, historic steel frames should be repaired. Often the corrosion is superficial; frames in this condition need prepping, painting with a good zinc-enriched paint, and realigning in the frame.

Masonry frames typically last a long time with few problems, but removing leaded glass panels set in hardened putty or mortar can be nearly impossible; as a last resort, glass borders may have to be sacrificed to remove the window.

Occasionally, leaded glass was designed or fabricated with inadequate bracing; this results in bulging or bowing panels; leaded panels should generally not exceed 14 linear feet (4.25 m) around the perimeter without support. More often, the placement of bracing is adequate, but the tie-wires that attach the leaded panels to the primary frame may be broken or disconnected at the solder joints.

Lead and zinc comes are the two most common assembly materials used in stained and other “leaded” glass. The strength and durability of the leaded panel assembly depends upon the type of came, the quality of the craftsmanship, and the glazing concept or design, as well as on the metallic composition of the comes, their cross-section strength, how well they are joined and soldered, and the leading pattern within each panel. Came is prone to natural deterioration from weathering and from thermal expansion and contraction, which causes metal fatigue.

The inherent strength of the assembly system is also related to the cross-section, profile and internal construction of

Came Types and Properties

Lead Came

Lead is a soft malleable metal (it can be scratched with a fingernail). It naturally produces a protective dark bluish-gray patina. In the mid-19th century, improved smelting processes enabled manufacturers to extract valuable metal impurities from lead, thereby producing 100% pure lead came. The industry reasoned that 100% pure lead came was superior to the less pure variety. Although pure lead came is very workable and contributes to intricate designs, time has proven it to be less durable than medieval came, which contained trace elements of tin, copper, silver, and antimony. Unfortunately, the misconception that pure lead had greater longevity continued throughout the glory years of leaded glass use in America. Most glass conservators use a 100-year rule of thumb for the general life expectancy of 19th century came. In the 1970s, “restoration lead” (ASTM B29-84) was developed based on metallurgic analyses of medieval comes, some of which have lasted for centuries. Restoration lead should always be used when releading historic windows, unless the original integrity will be compromised.

Zinc Came

Zinc came is more vulnerable to atmospheric corrosion (particularly from sulfuric acids) than lead, but has proven to be durable in America because it weighs 40% less than lead and its coefficient of expansion is 7% lower. Thus, it is somewhat less susceptible to fatigue from expansion and contraction. Moreover, it is ten times harder than lead, and has three times the tensile strength. Zinc came is strong enough to be self-supporting and requires little bracing to interrupt the window’s design. While zinc came is perfect for the geometric designs of Prairie School windows, it is usually too stiff to employ in curvilinear designs. Zinc can also take several finishes, including a copper or black finish. (As a result, zinc can be mistaken for copper or brass.)

Other Came

Other metals, primarily solid brass and copper, were also occasionally employed as came. They are generally found only in windows between ca. 1890 and ca. 1920. Frank Lloyd Wright started with zinc in 1893, was plating the zinc with copper by the late 1890s, and using solid copper by 1906.

the came (Fig. 13). Came can have a flat, rounded, or “colonial” profile, and aside from a few specialty and perimeter comes (U-channel), is based on a variation of the letter “H” and ranges from 1/8” (3.2mm) wide to 1½” (38mm) wide. The cross-section strength of came varies depending on the thickness of the heart and flanges. Occasionally, came with reinforced (double) hearts or a steel core was used for rigidity, usually in doors and sidelights. Such came added strength at the expense of flexibility and was typically used for rectilinear designs, or for strategically placed reinforcement within a curvilinear design.

How the comes are joined in a leaded panel is crucial to their long-term performance. Poor craftsmanship leads to a weak assembly and premature failure, while panels fabricated with interlocking (weaving) comes and lapped leads add strength. Soldered joints often reveal the skill level of the artisan who assembled the window, and can give evidence of past repairs. Solder joints should be neat and contact the heart of the came—wherein lies its greatest strength. Came joints should be examined closely; large globs of solder commonly conceal comes that do not meet. (Lead comes typically crack or break along the outside edge of the solder joint; stronger zinc comes frequently break the solder itself where it bridges junctures.)

Leading patterns designed with inadequate support also contribute to structural failure. Panels with a series of adjacent parallel lines tend to hinge or “accordion,” while lines radiating in concentric circles tend to telescope into a bulge. Stronger leading techniques, support bars, or specialty comes are sometimes required to correct poor original design. Minor sagging and bulging is to be expected in an old window and may not require immediate action. However, when bulges exceed 1½” (38mm) out of plane, they cross into a precarious realm; at that point, glass pieces can crack from severe sagging and pressure. If the bulged area moves when pressed gently, or if surrounding glass is breaking, it is time to address the problem before serious failure results.

Cleaning, Repair and Protection

The level of cleaning, repair, or protection depends on the condition, quality, and significance of the glass, and, as always, the available budget. Hastily undertaken, overly aggressive, or poorly executed repairs can cause more damage than does prolonged deterioration. Repairs should, therefore, only be undertaken after carefully evaluating the condition of the glass—and only by professionals. Minor cracks, sagging, and oxidation are part of the character of historic leaded glass, and require no treatment. More extensive cracks, major bulges (generally, more than 1½” [38mm]), and other signs of advancing deterioration may call for intervention, but caution must always be exercised. And each window must be evaluated separately. In

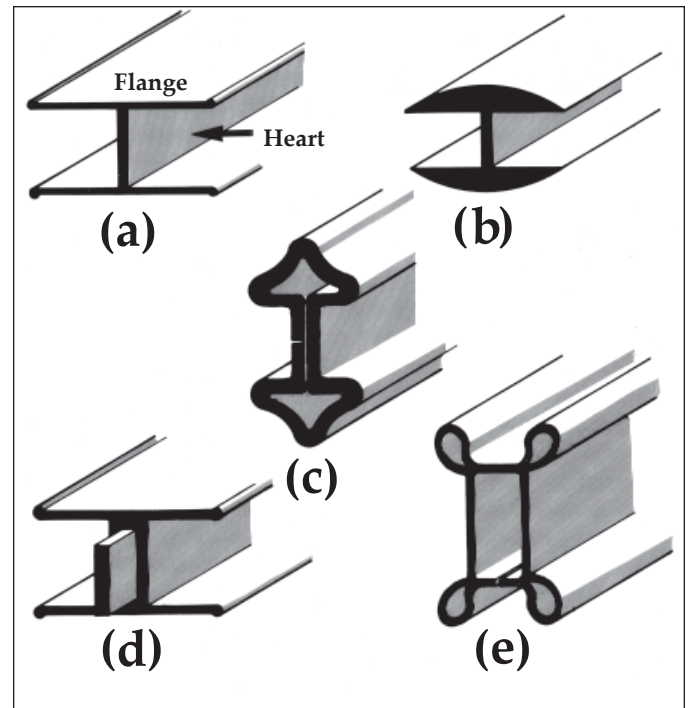

Figure 13. A wide variety of came has been used for ornamental glass in America: (a) flat lead came; (b) round lead came; (c) “Colonial” zinc came; (d) double-heart lead came with a steel core; (e) “Prairie School” zinc came.

some cases, windows have bulged up to 4” (102mm) out of plane without harming the pieces of glass or risking collapse.

Cleaning

Perhaps the greatest virtue of stained glass is that its appearance is constantly transformed by the ever-changing light. But dirt, soot, and grime can build up on both sides of the glass from pollution, smoke, and oxidation. In churches the traditional burning of incense or candles can eventually deposit carbon layers. These deposits can substantially reduce the transmitted light and make an originally bright window muted and lifeless. Simply cleaning glass will remove harmful deposits, and restore much of its original beauty, while providing the opportunity to inspect its condition closely (Fig. 14). The type of cleaner to use depends on the glass. Water alone should be tried first (soft water is preferable); deionized water should be used for especially significant glass and museum quality restorations. If water alone is insufficient, the next step is to use a non-ionic detergent. Occasionally, windows are covered with a yellowed layer of shellac, lacquer, varnish, or very stubborn grime that requires alcohol, or solvents to remove. Most unpainted art glass can be treated with acetone, ethanol, isopropyl alcohol, or mineral spirits to remove these coatings if gentler methods have failed. All chemical residues must then be removed with a non-ionic detergent, and the glass rinsed with water. (All workers should take normal protective measures when working with toxic chemicals.)

Painted glass must never be cleaned before the stability of the paint is confirmed, and only then with great caution. If the paint is sound, it can be cleaned with soft sponges and cloth. If the paint was improperly fired or simply applied cold, paint can flake off during cleaning and special measures are required such as delicate cleaning with cotton swabs. Occasionally, paint is so fragile the owner must simply document and accept the windows in their current state rather than risk losing the original surface. Fragile paint typically calls for an experienced glass conservator and more costly restoration measures.

Acidic, caustic, or abrasive cleaners should never be used. They can damage glass. Most common household glass cleaners contain ammonia and should not be used either. Cleaning products should have a neutral pH.

Repair

As with all elements in older and historic buildings, maintenance of leaded glass units is necessary to prevent more serious problems. It is essential to keep the frame maintained regardless of the material. Often, this simply entails regular painting and caulking, and periodic replacement of the glazing compound. Wood frames should be kept painted and caulked; new sections should be spliced into deteriorated ones, and epoxy repairs made where necessary. Masonry frames must be kept well pointed and caulked to prevent moisture from corroding the steel armature and anchors within.

Windows that leak water, are draughty, or rattle in the wind (or when gently tapped) may indicate that the waterproofing cement (“waterproofing”) and sealants have deteriorated and maintenance or restoration is needed. Waterproofing is a compound rubbed over the window—preferably while flat on a table—and pressed under the came flange to form a watertight bond between the leading and the glass. Traditionally, waterproofing was made of linseed oil and whiting, and a coloring agent. (Hardening agents should not be included in the mixture; solvent-based driers should be used sparingly.) The waterproofing allows leaded glass in a vertical position (e.g., in windows) to be used

as a weatherproof barrier. It does not provide adequate protection for leaded glass in a horizontal or arched position; leaded glass ceilings and domes must always be protected by a secondary skylight or diffusing skylight.

Glazing and sealants (e.g., putties, caulks) are used to seal the leaded panel against the sash, and to seal any open joints around the window frame. Sealants improved dramatically in the mid-twentieth century. But these sealants are not without problems. Some release acetic acid as they cure. Acetic acid can harm lead, and should never be used on leaded glass. Instead, “neutral cure” sealants should be used. These high-performance construction sealants are not sold in consumer supply stores.

The appropriate type of sealant depends on the materials to be bonded and on the desired appearance and longevity. When windows are to be restored, the contractor should explain what types of waterproofing and sealants are to be used, and how long they are expected to last. On large projects, a letter from the product manufacturer should be obtained that approves and warrants the proposed application of their product. When in doubt, a traditional linseed-oil based glazing putty is often best.

Leaded panels will generally outlast several generations of waterproofing. When the waterproofing has failed, the window should be removed from the opening and waterproofed on a bench. Leaded glass cannot be adequately waterproofed in place. Removing the windows will provide an opportunity to perform maintenance on the window surround and to secure the reinforcement. This is far less expensive than totally releading the window, which is typically required if maintenance is deferred. When waterproofing or sealants break down, many building owners attempt to resolve the problem by installing protective glazing, when the window only needs maintenance. Protective glazing is not an alternative to maintenance; in fact, it impedes maintenance if not installed properly and can accelerate the deterioration of the stained glass.

A very common—but extremely harmful—practice in the American stained glass industry is performing major window repairs in place. The practice is routine among churches where the cost of restoring large windows can be prohibitive. However, undertaking major repairs in place provides only a quick fix. A window cannot be properly repaired or restored in place if it is bulging or sagging far out of plane, if over 5% of the glass is broken, or if solder joints are failing. Unscrupulous glaziers can introduce a great deal of stress into the glass by forcibly flattening the window in place and soldering on additional bracing. At a comfortable distance the window may look fine, but upon close inspection the stress cracks in the glass and broken solder joints become obvious. Windows subjected to this treatment will deteriorate rapidly, and complete, much more costly restoration will likely be necessary within a few years (while a proper repair can easily last two generations or more).



Figure 14. The external glass plate has been removed to clean the interlayer of this plated Tiffany Studios window.

Major repairs to windows are sometimes part of a larger preservation project. In such cases, the risk of damaging the windows can be very great if their removal and reinstallation have not been carefully planned. When major building repairs are also to take place, the windows should be removed first to prevent damage during other work. Windows should be reinstalled as the next-to-last step in the larger project (followed by the painters or others working on the finishes surrounding the stained glass).

And glass should be protected whenever other work is undertaken on buildings—whether or not the windows are also to be repaired. External scaffolding, for example, erected for repointing or roofing projects, may offer vandals and thieves easy access to windows and, through them, to building interiors. Stained and leaded glass should always be well protected whenever chemical cleaners are used on the exterior of the building; some products, such as hydrofluoric-acid cleaners, will cause irreversible damage.

Repairs to Glass

Minor repairs, such as replacing a few isolated pieces of broken glass, can be performed in place. This work, typically called a “drop-in,” “stop-in,” or “open-lead” repair, entails cutting the came flange around the broken piece of glass at the solder joints, folding it back to repair or replace the old glass, and resoldering the joints. Repairing a zinc came window is not as easy. Zinc comes are too stiff to open up easily, so they must be cut open with a small hack saw and dismantled until the broken area is reached. The glass is then repaired or replaced and the window is reassembled. New comes can be patinated to harmonize with the originals—but only with difficulty. Repatination should never be attempted in place, since it is impossible to clean off harmful residues trapped under the came.

Original glass should be retained whenever possible, even though it may be damaged. Replacement glass that exactly or closely matches the original piece can be very difficult to find, and costly to make. An endless variety of glass colors and textures were produced, and given the delicate chemistry of glassmaking, even samples from the same run can be noticeably different. The traditional

Photographing Stained Glass

Historic stained glass windows, laylights and domes should be documented to help ensure the best-quality restoration in the event of vandalism, fire or other loss. Photographic documentation is also important for insurance and investigation purposes when vandalism or theft is involved. Given the highly photogenic nature of stained glass, photographs can also serve as artwork for guidebooks or other interpretive or publicity purposes; quality photographs can be especially worthwhile in fundraising efforts.



Photographing stained glass is both challenging and rewarding. Windows and domes lit by daylight can seem to be ever changing in visual appearance. They can appear dramatically different in any given photograph depending not only on the photographic equipment and settings used, but also on the time of day, degree of cloud cover, the ambient interior light, and a multitude of other factors. Moreover, photographs may differ depending on the aspect to be captured. Painted flesh areas and highly translucent Prairie School windows often “burn out” if photographed in bright sunlight, while faceted jewels and very dense or plated opalescent glass often look best in direct sunlight.

Generally, exposures should be bracketed to capture the full range of the stained glass; the variation in images can permit different images to serve different purposes. Under most circumstances, interior lights should be turned off, and the stained glass should be photographed in both transmitted light (no flash) and reflected light utilizing a flash. The flash should ideally be positioned away from the camera to provide a raking light and to avoid reflected “hot spots.” Although photographing with a flash will neutralize the transmitted light and black out the glass, it reveals the location and condition of the lead comes, braces, tie-wires, and other structural elements.

A tripod should be employed for a sharp image whenever using long exposures and higher apertures. The subject should be shot as level as possible to minimize the distortion known as “parallax.” Occasionally, when shooting a group of windows, it is beneficial to develop a cardboard, Ecuboard, Masonite or similar cutout material to mask the window being photographed. Adjacent windows or windows on the opposite side of the room may need to be shaded or blocked to avoid “front lighting” on the window from competing with the transmitted light. Windows should also be photographed from the outside if there is no protective glazing to interfere with the view. This is particularly important with opalescent glass, which often was intended to be read from the exterior as well as the interior.

Some glass projects warrant a visual representation of the stained glass window to be in place during restoration. After establishing the existing window dimensions, a photograph of the stained glass window can be enlarged to full scale and copied on adhesive-backed transparent film. In essence a decal, it can then be applied to acrylic or polycarbonate sheets and used as a temporary replacement to fill the opening (above). Such film decals are sensitive to light and will not last indefinitely. However, they are reasonably convincing from a distance and can last a year or longer while the actual window is being restored.

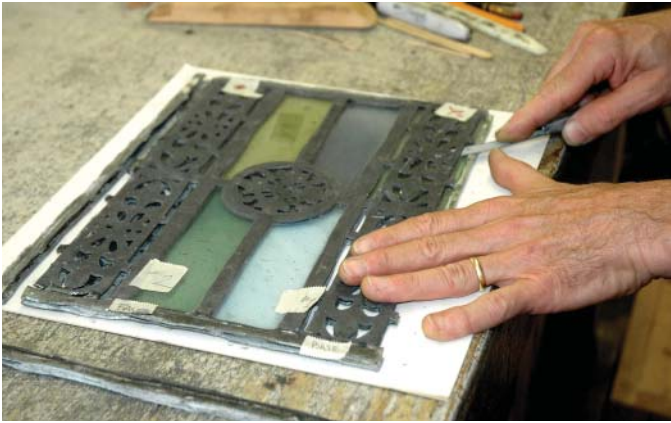

Figure 15. To permit repair of the cracked glass, the original lead overlay is first salvaged from this historic leaded panel of silhouette glass to retain as much of the original work as possible.



Figure 16. A valuable historic piece of original hand-painted glass is carefully edge-glued with epoxy.

secrecy that shrouds the glassmaking trade to this very day, as well as environmental bans of historically popular ingredients such as lead and cobalt for deep blues and greens, further hinders accurate reproductions. Therefore, *it is nearly always better to use an imperfect original piece of glass than to replace it* (Fig. 15). If the paint is failing on a prominent feature of a window, a coverplate of thin, clear glass can be painted and placed over the original. (The coverplates must be attached mechanically, rather than laminated, so that they can be removed later if necessary.) A reverse image of the fading feature should be painted on the backside of the coverplate in order to get the two painted images as close together as possible. With repetitive designs, stencils can be created to produce multiple duplicates.

Sometimes replacement is the only option. Fortunately, custom glass houses still exist, including the company that originally supplied much of the glass for Tiffany commissions. Stained and leaded glass has also experienced a resurgence in popularity, and American glassmakers have revived many types of historic glass.

When missing, shattered, or poorly matched glass from later repairs must be replaced, the new pieces should be scribed on the edge (under the came) with the date to prevent any confusion with original glass in the future.

Glass cracks will enlarge over time as the contacting edges grind against each other, whenever the window is subject to vibration, thermal expansion and contraction, and other forces such as building movement. Therefore, it is important to repair cracks across important features as soon as they are detected and while a clean break remains. Years ago, cracks were typically repaired with a “Dutchman” or “false lead” by simply splicing in a cover lead flange over a crack. Although this conceals the crack, it creates an even larger visual intrusion and provides no bond to the glass. Today, there are three primary options for repairing broken glass: copper foil, epoxy edge-gluing (Fig. 16), and silicone edge-gluing. These techniques differ in strength, reversibility, and

visual effect, and the appropriate repair must be selected on a case-by-case basis by a restoration specialist.

Copper Foiling: Copper foil has the longest history and, unless the glass is unstable, is generally the best option when a piece of glass has only one or two cracks. Copper foil is a thin tape that is applied along each side of the break, trimmed to a minimal width on the faces, and soldered. A copper wire can be soldered on where additional strength is required. However, copper foil repairs should not be used on unstable glass, since heat is required that can cause further damage. Copper foil produces a strong repair, is totally reversible, and has a negligible aesthetic impact (a 1/16” [1.6mm] wide line).

Epoxy Edge-Gluing: This technique produces a nearly invisible line and is often used on painted glass, particularly focal points of a window such as a face, or a portion of sky intended to be one continuous piece. Epoxy can even be tinted to match the glass. It is also used for infusing shattered glass or microscopic cracks caused by intense heat from a fire. Epoxy produces a very strong repair, but will deteriorate in sunlight and requires secondary glazing to protect it from UV degradation. Epoxy is the least reversible of the three techniques, and usually the most expensive.

Silicone Edge-Gluing: This repair method has the lowest strength and should be used when a flexible joint is desirable—if, for instance, the window will be under continuous stress. Silicone repairs are easily reversible, and can be removed with a razor blade—when they are done correctly, that is. Silicone edge-gluing is not the same as smearing silicone all over the glass. This unfortunate practice, seen throughout the country, is useless as a repair technique, and usually causes more damage than if the glass were left alone. Silicone is almost clear, but it refracts light differently from glass and is, thus, easily detectable. Silicone is not affected by temperature, humidity or UV light. Silicone repairs are typically the least expensive repair option.

Repairs to Structural Support Systems

Windows may have detached from the saddle bars and begun to sag, bulge, and bow extensively. This point varies from window to window. Generally, however, a window sagging or bulging more than 1½" (38mm) out of plane has reached the point where it should be removed from the opening to be flattened out. Under these conditions, it is essential to note if the support system or leading pattern has failed so it may be corrected before the window is reinstalled. The window must be allowed to flatten over a few weeks in a horizontal position. This will minimize stress on the solder joints and glass. A moderate weight and controlled heat will help coax the window back into its original plane. The process requires patience. Once the window has flattened, the original support system should be reattached and additional support added as necessary. It is crucial to consider the original design so the new support bars do not intrude on important window features. Sometimes small thin braces or "fins" can be manipulated to follow existing lead lines exactly. These give support, but are almost invisible. Flattening windows also provides a good opportunity to apply new waterproofing to help prevent further deterioration. Today, a wide variety of traditional and synthetic compounds are employed.

Windows should only be removed when they need to be flattened, waterproofed, reinforced, or reled. Allow plenty of time for careful, thorough work. Large projects can take several months, especially if complete releading is necessary. Owners, consulting professionals, and construction managers must therefore ensure that vacant openings will be weathertight for an extended period—whether the openings are covered by plywood, acrylics, or polymer film. If desired, images of the window can be printed on adhesive film and applied to rigid plastic and installed in the openings as temporary facsimiles during studio restoration.

Rebuilding or releading a window is an expensive and involved process. The releading process requires that a window be disassembled before it can be reassembled (Fig. 17). The glass pieces must be removed from the cames, the old cement must be cleaned from each piece of glass, and all the pieces must be rejoined precisely. At every step the process involves the risk of damaging the glass. Furthermore, exceptional studios had unique leading techniques, and thus the cames should not be replaced casually. Total releading should only be undertaken when necessary to avoid or slow the loss of historic fabric. (It is essential to request a copy of all window rubbings if the windows are to be completely reled.)

Lead and zinc cames, however, are intended to be a sacrificial element of a glass unit assembly, as mortar is to brick and paint is to wood; came will break down long before glass and must ultimately be replaced; came typically lasts 75 to 200 years depending on the window's quality, design and environment. A common preservation

conflict arises in releading historic windows: whether to retain historical accuracy by using the existing profile, or to use came with a stronger profile for greater longevity. The decision must be carefully weighed depending on the significance of the window, the contribution of the came profile to the overall design, and the severity of the deterioration caused by a thin or weak came. In most windows, the came profile is essentially lost in transmitted light, but occasionally shadow lines are important and should be reproduced. Furthermore, it is important to correct technical problems that arise from flimsy original came. Occasionally, a slightly heftier came may be the best solution to resolve weak panels that have not proven the test of time. Under these circumstances, the thicker lead came (even if only 1/64" [0.4mm]) will cause a re-led panel to swell slightly, and the frame or perimeter leads may have to be trimmed to fit the opening. (Trimming the glass should be the very last resort.) This would not be an appropriate solution in a museum-quality restoration or for a highly significant window.

Protective Glazing and Screens

The use of protective glazing (also known as secondary or storm glazing) is controversial. Potential benefits of protective glazing are that it can shield windows from wind pressure; increase energy savings; protect against environmental pollutants and UV light; provide vandalism and security protection, and reduce window maintenance. Potential drawbacks are that it can promote condensation; cause heat to build up in the air space and thereby increase the window's expansion/contraction; eliminate natural ventilation; reduce access for maintenance; offer a poor energy payback for the cost, and significantly mar the building's appearance. Protective glazing is often presented as a cheaper alternative to full-scale restoration. And all too often protective glazing is installed as a routine matter when there is little threat of damage from vandalism or other causes. Protective glazing, especially when improperly installed, may hasten deterioration of stained glass windows.



Figure 17. Total releading is very time consuming and costly and should only be undertaken when the original lead is exhausted beyond repair.

Domes and Ceilings

Stained glass domes and ceilings were very popular throughout the Victorian and Classical Revival periods. They are often principal interior features of churches, hotels, restaurants, railway stations, and civic buildings. The loss or unsympathetic alteration of leaded glass ceilings and domes is a widespread problem. Poorly planned rehabilitation projects sometimes cause the unnecessary removal or alteration of overhead leaded glass in order to comply with fire codes or to achieve perceived energy savings; occasionally, they are even concealed above suspended ceilings.

Moreover, stained glass in the horizontal position readily collects dust and dirt over the years and is relatively inaccessible for cleaning. It is also more likely to “creep” or slump when the reinforcement is inadequate. Most importantly, leaded glass cannot be sufficiently weatherproofed in a horizontal (or arched) position. It must *always* be protected by skylights or “diffusers” — rooftop features that diffuse the natural daylight into the attic or light shaft, and protect the leaded glass ceiling or dome from the elements (a).

Due to the inferior quality of glazing sealants of the late 19th and early 20th centuries, and to deferred maintenance, glass ceilings have frequently been removed or covered with roofing materials. Artificial lighting is then required to backlight the ceiling or dome, which robs the stained glass of its life—the vibrant effects created by ever-changing natural light. All types of artificial lighting can be found from floodlamps to fluorescent tubes. Outside sensors are even used to modulate the light level in an attempt to simulate changes in daylight. However, daylight is impossible to emulate. Moreover, it’s free. Artificial lighting requires maintenance, introduces an additional fire hazard in the attic, increases the building’s electrical load, and is supplied only at a financial and environmental cost.

Stained glass ceilings and domes that have been sealed off from natural light should be investigated for restoration. Once natural light is restored and the stained glass is cleaned, the lighting effect on an interior can be extraordinary. Improved skylight designs and major advances in glazing sealants since World War II (particularly silicones) encourage the restoration of skylights without the fear of inheriting a maintenance nightmare (b).

(b) Workers install a jeweled art glass oculus of a Healy & Millet dome. The diffusing skylight was restored overhead to reintroduce daylight to the historic 1897 dome after being roofed over since the 1940s.

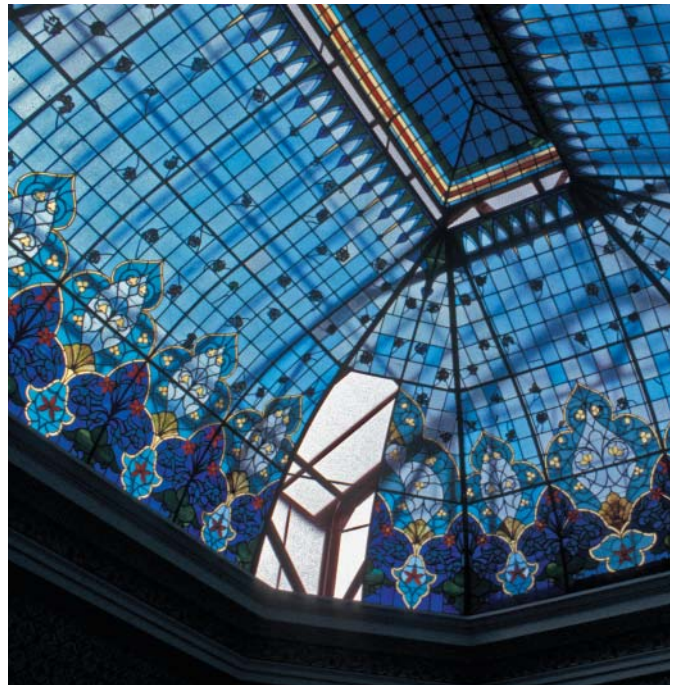

(a) Stained glass ceilings and domes are often principal interior features of churches, hotels, restaurants, railway stations, and civic buildings. This vaulted ceiling illuminates the Cypress Lawn Memorial Gardens mausoleum in Colma, California. The panel removed reveals the diffusing skylight above.

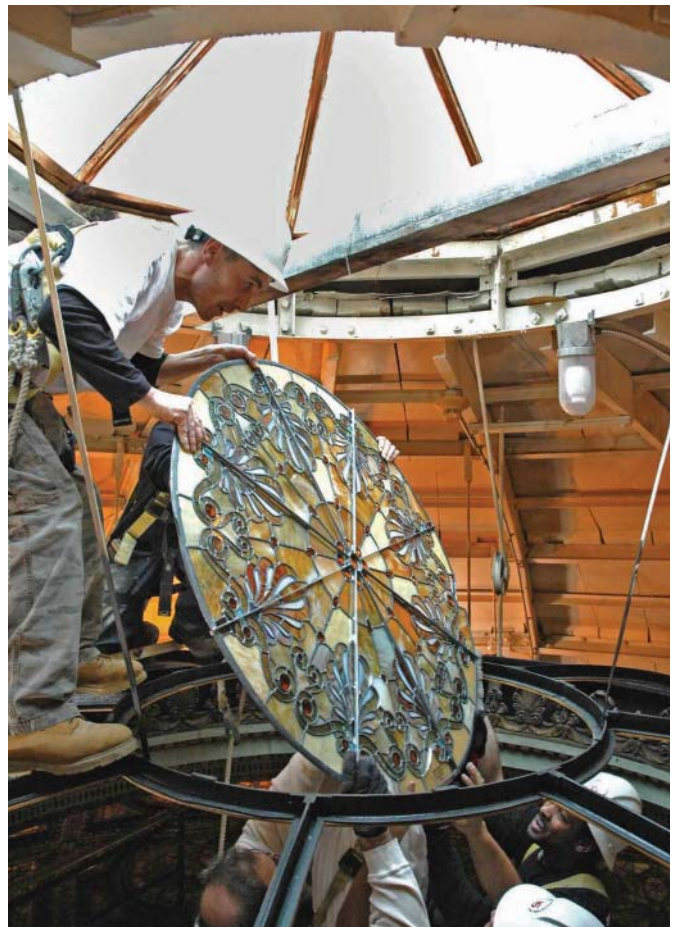

Figure 18. On this pair of neo-gothic church windows, the aluminum frame grid used for protective glazing disregards the original tracery of the window on the left. The grid mars the appearance of the window inside and out. It also impairs the overall historic character of the building. The plastic storm glazing has been removed from the adjacent window to restore the original window appearance.



Various types of metal grills or screens are also used. They add security and vandalism protection but also impair the appearance of the window (inside and out) by creating new shadows that telegraph on the stained glass or diffusing transmitted light. As a general rule, protective layers should not be added on historic buildings unless the glass setting was designed for storm glazing. In most cases the potential drawbacks outweigh the potential benefits.

Under some circumstances, however, protective glazing or screens may be necessary. (This applies to windows. Domes and ceilings present a special case. See “Domes and Ceilings”). A real vandalism or security threat warrants protective glazing, such as when the windows can be reached easily or are in an isolated location. Protective glazing is also warranted when employed historically on a particular window as original plating (Tiffany Studios, for example, often used plate glass to keep dirt and moisture out of their multi-plated windows). Unusual circumstances (such as when the windows are painted on the outside) may also dictate the use of protective glazing. Finally, protective glazing is warranted when a UV filter is needed to prevent epoxy glass repairs from breaking down.

A variety of protective glazing materials are available. They include polycarbonates, acrylics, laminated glass, plate glass, and tempered glass. The plastic products are very strong, lightweight, and relatively easy to install, but will scratch, haze, and yellow over time, despite UV inhibitors. They also have a high coefficient of expansion and contraction, so the frames must be designed to accommodate change induced by temperature fluctuations. Poor installations in restrictive frames cause distorted reflections from bowing panels often damaging the historic frame. Protective panels of glass are heavier and more difficult to install, making them more expensive than plastic. However, glass will not bow, scratch, or haze and is usually the best option in aesthetic terms; laminated glass provides additional impact resistance.

A common error in installing protective glazing is to create a new window configuration (Fig. 18). Insensitive installations that disregard the original tracery destroy the window’s aesthetics—and the building’s. When protective glazing is added, it should be ventilated. If a window is not ventilated, heat and condensation may build up in the air space between the ornamental glass and the protective glazing (creating a “greenhouse effect”).

When absolutely necessary, protective glazing should be installed in an independent frame between $\frac{5}{8}$ ” (16mm) and 1” (25mm) from the leaded glass. This allows the protective panel to be removed for periodic maintenance of both the historic window and the new glazing. The conditions of the air space between the two layers should be monitored on a regular basis; condensation should never collect on the window.

No ideal formulas have been developed for venting the air space between the ornamental glass and the protective glazing, but it is typically vented to the outside (unless the building is air conditioned most of the year). Generally, a gap of several inches is left at the top and bottom when glass is used, or holes are drilled in the protective glazing at the top and bottom when polycarbonates and acrylics are used. Small screens or vents should be added to keep out insects. Finally, it is important to realize that most original plating was “rough plate” or “ribbed” and never had a modern polished reflection. Some glass tinted the transmitted light intentionally, as originally designed: in this case any new or replacement plating should simulate this effect to respect the artisan’s intention.

Conclusion

Much of the Nation’s stained glass and leaded glass has recently passed, or is quickly approaching, its 100th anniversary—yet much of this glass has not been cleaned or repaired since the day it was installed. With proper care, the stained and leaded windows, transoms, and other elements that add so much to historic buildings can easily last another century.

Selected Reading List

Duthie, Arthur Louis. *Decorative Glass Processes: Cutting, Etching, Staining, and Other Traditional Techniques*. New York: The Corning Museum of Glass and Dover Publications, 1982.

Fisher, Charles E., III, ed. *The Window Handbook: Successful Strategies for Rehabilitating Windows in Historic Buildings*. Washington, D.C.: National Park Service and Georgia Institute of Technology. 1986. Rev. 1990.

Fisher, Charles E., III, Deborah Slaton, and Rebecca A. Shiffer, eds. *Window Rehabilitation Guide for Historic Buildings*. Washington, D.C.: Historic Preservation Education Foundation/National Park Service, 1997.

Heinz, Thomas A. *Lloyd Wright Glass Art*. Academy Editions, Ernst & Sohn, 1994.

Heinz, Thomas A. "Use & Repair of Zinc Comes in Art-Glass Windows." *Old House Journal*, (September/October 1989), pp. 35-38.

Lee, Lawrence, George Seddon and Francis Stephans. *Stained Glass*. New York: Crown Publishers, 1976.

Lloyd, John Gilbert. *Stained Glass in America*. Jenkintown, PA: Foundation Books, 1963.

Stained Glass Association of America. *SGAA Reference & Technical Manual*, Second Edition Lee's Summit, MO: The Stained Glass Association of America, 1992.

Wilson, H. Weber. *Great Glass in American Architecture: Decorative Windows and Doors Before 1920*. New York: E. P. Dutton, 1986.

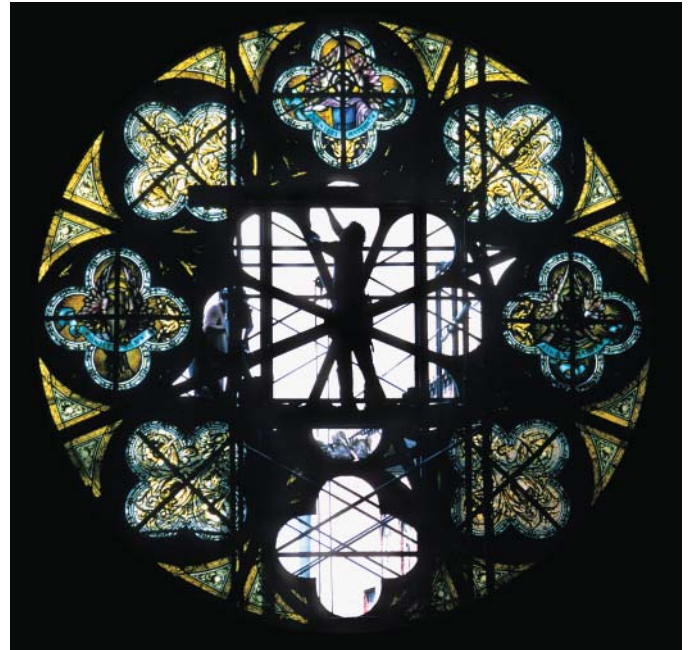

Wooden frame of the rose window undergoing repair (exterior view).

Cover Photograph: Tiffany Studios opalescent art glass frame from 1914, originally installed in a dome over the Men's Grill in Marshall Field's, Chicago.

Acknowledgements

Neal A. Vogel is the Principal of Restoric, LLC, Evanston, Illinois. Rolf Achilles is an Art Historian and Curator of the Smith Museum of Stained Glass Windows at Navy Pier, Chicago. All drawings and photographs by Neal A. Vogel unless otherwise stated.

Michael J. Auer, Technical Preservation Services, National Park Service, served as technical editor. Additional assistance was provided by Charles Fisher, Anne Grimmer, and former staff Chad Randl, Technical Preservation Services.

The authors would like to thank the following for sharing information and providing opportunities to review works in progress: Botti Studios of Architectural Arts, Evanston, IL; Chicago Metallic Corporation, Chicago, IL; Chicago Art Glass and Jewels, Inc., Cedar Grove, WI; Conrad Schmitt Studios, Inc., New Berlin, WI; Cypress Lawn Memorial Park, Colma, CA; Hollander Glass, Stanton, CA; Mary Clerkin Higgins, New York, NY; Venturella Studios, New York, NY; Wardell Art Glass, Aurora, IL. Special thanks for providing editorial assistance to Arthur J. Femenella, Femenella & Associates, Branchburg, NJ; Richard L. Hoover, Stained Glass Association of America, Lee's Summit, MO; and H. Weber Wilson, Oltz-Wilson Antiques, Portsmouth, RI.

This publication has been prepared pursuant to the National Preservation Act of 1966, as amended, which directs the Secretary of the Interior to develop and make available information concerning historic properties. Comments about this publication should be addressed to: Charles Fisher, Technical Publications Program Manager, Technical Preservation Services—2255, National Park Service, 1849 C Street, NW, Washington, D.C. 20240. This publication is not copyrighted and can be reproduced without penalty. Normal procedures for credit to the authors and the National Park Service should be provided. The photographs used in this publication may not be used to illustrate other publications without permission of the owners. For more information about the programs of the National Park Service's Technical Preservation Services, see our website at www.nps.gov/history/hps/tps.

ISSN: 978-0-16-078947-2

U.S. Government Printing Office Stock Number: 024-005-01254-1

October 2007