

Garden Bench

YellaWood
Pressure Treated Pine

This sturdy garden bench is so simple to build you can have it completed in less than a day – including sanding and finishing. Made entirely from dimensional lumber and with only simple cuts and butt joints, you can build it on Saturday and be enjoying it Sunday morning.

The most complicated aspect of this bench is laying out and cutting the arms – and even that is a simple, straightforward task. Here we cut and sanded a round arm profile, but feel free to play with the design and use a couple of 45-degree cuts to “round” the front of the arms... or whatever suits your tastes.

BUILD TIME

Cutting parts: 2 hours

Assembly: 1 hour

Finishing: 2 – 3 hours

Total: 5 – 6 hours

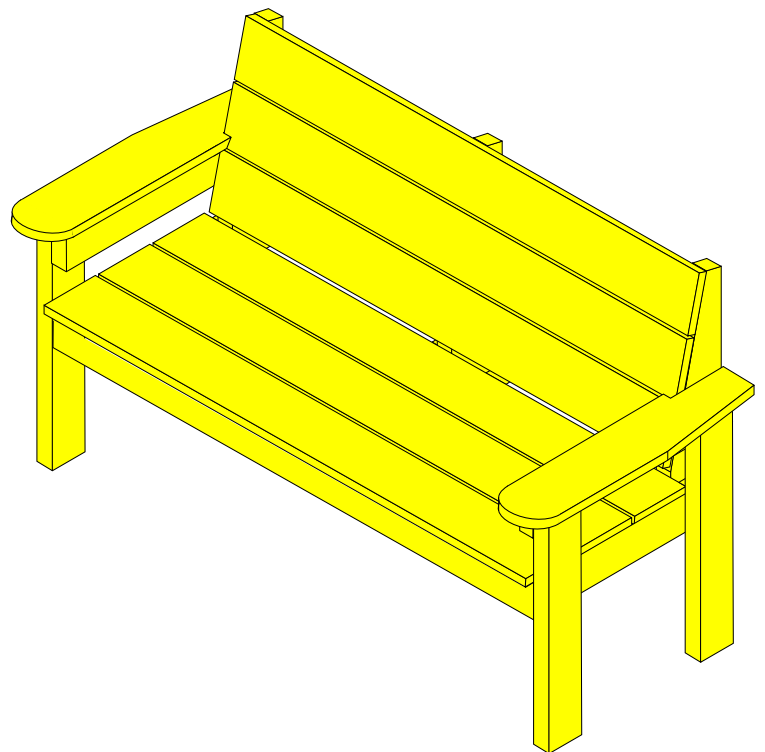

Garden Bench

YellaWood
Pressure Treated Pine

TOOLS

*Note: Drill pilot holes for all screws

Miter saw (or circular or hand saw)

Jigsaw

Drill/driver

1/8" drill bit

Clamps (2)

Damp rag to wipe up excess glue

SUPPLIES

(6) 1 x 6 x 8'

(5) 2 x 4 x 8'

(1) 2 x 6 x 8'

2" deck screws

2 1/2" deck screws

3" deck screws

Waterproof wood glue

CUT LIST

A	(4)	1 1/2 x 3 1/2 x 23 1/2"
B	(2)	1 1/2 x 3 1/2 x 23"
C	(2)	3/4 x 5 1/2 x 25"
D	(2)	1 1/2 x 3 1/2 x 54"
E	(4)	1 1/2 x 3 1/2 x 20"
F	(3)	3/4 x 5 1/2 x 54"
G	(3)	1 1/2 x 5 1/2 x 21 3/8"
H	(3)	3/4 x 5 1/2 x 51"

A



B



C



D

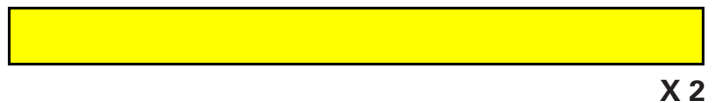

E



F

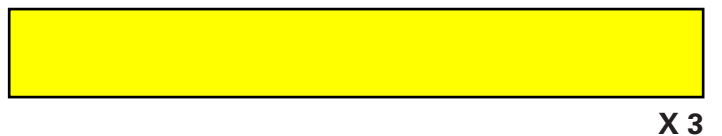

G



H



Garden Bench

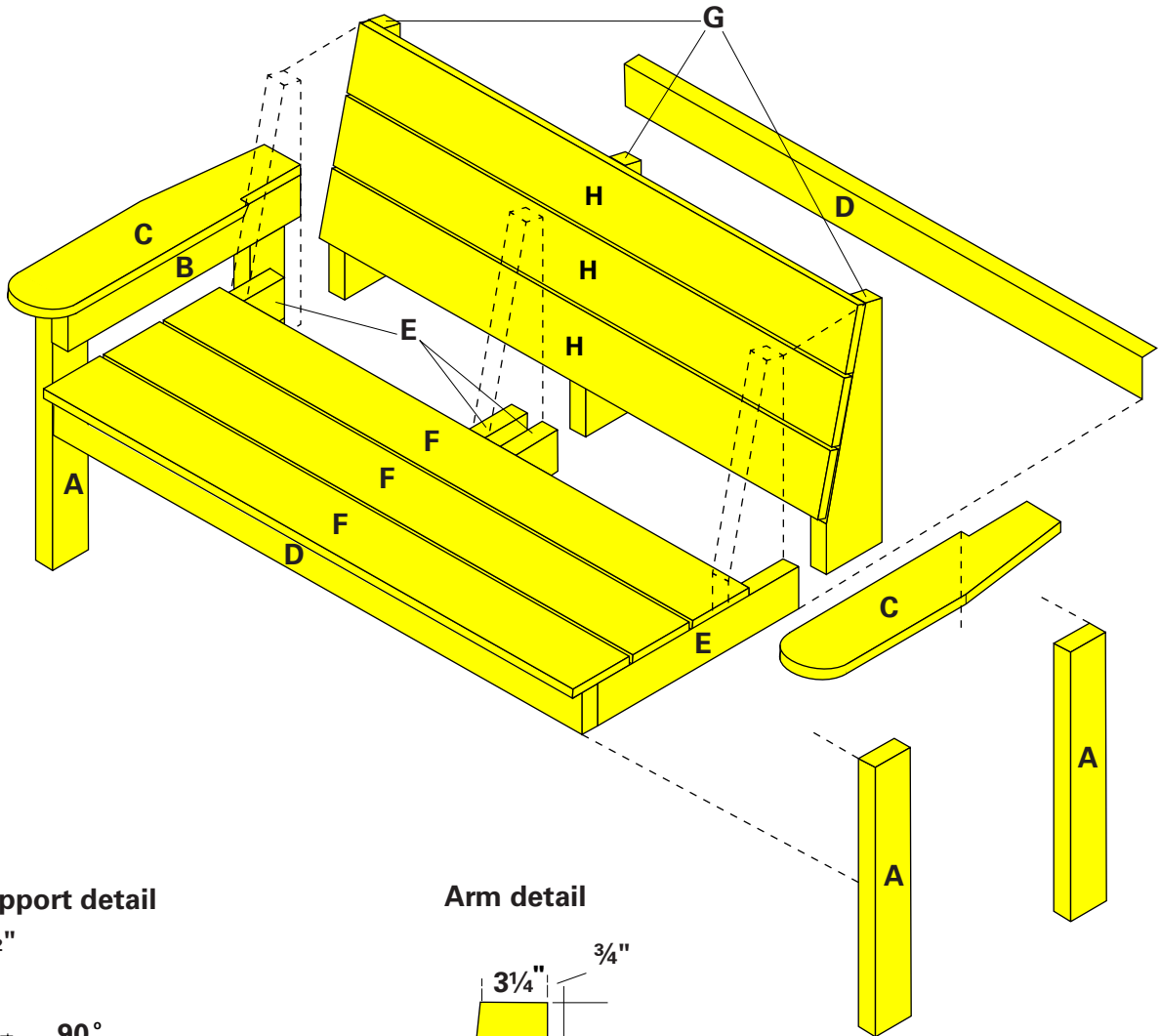

Back support detail

1½"

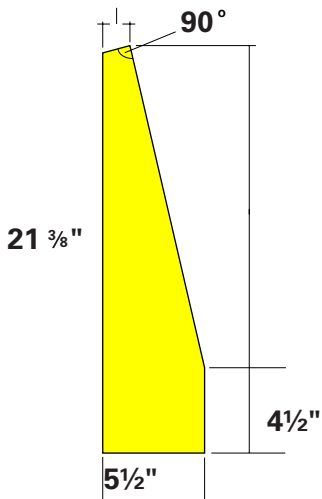

Arm detail

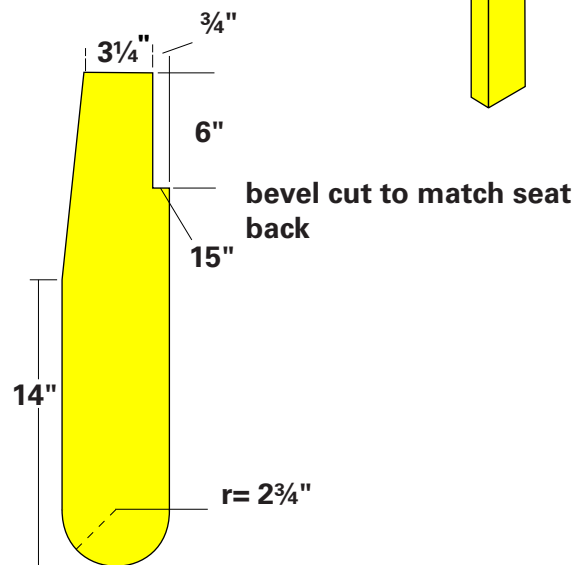

Garden Bench



Front view & dimensions

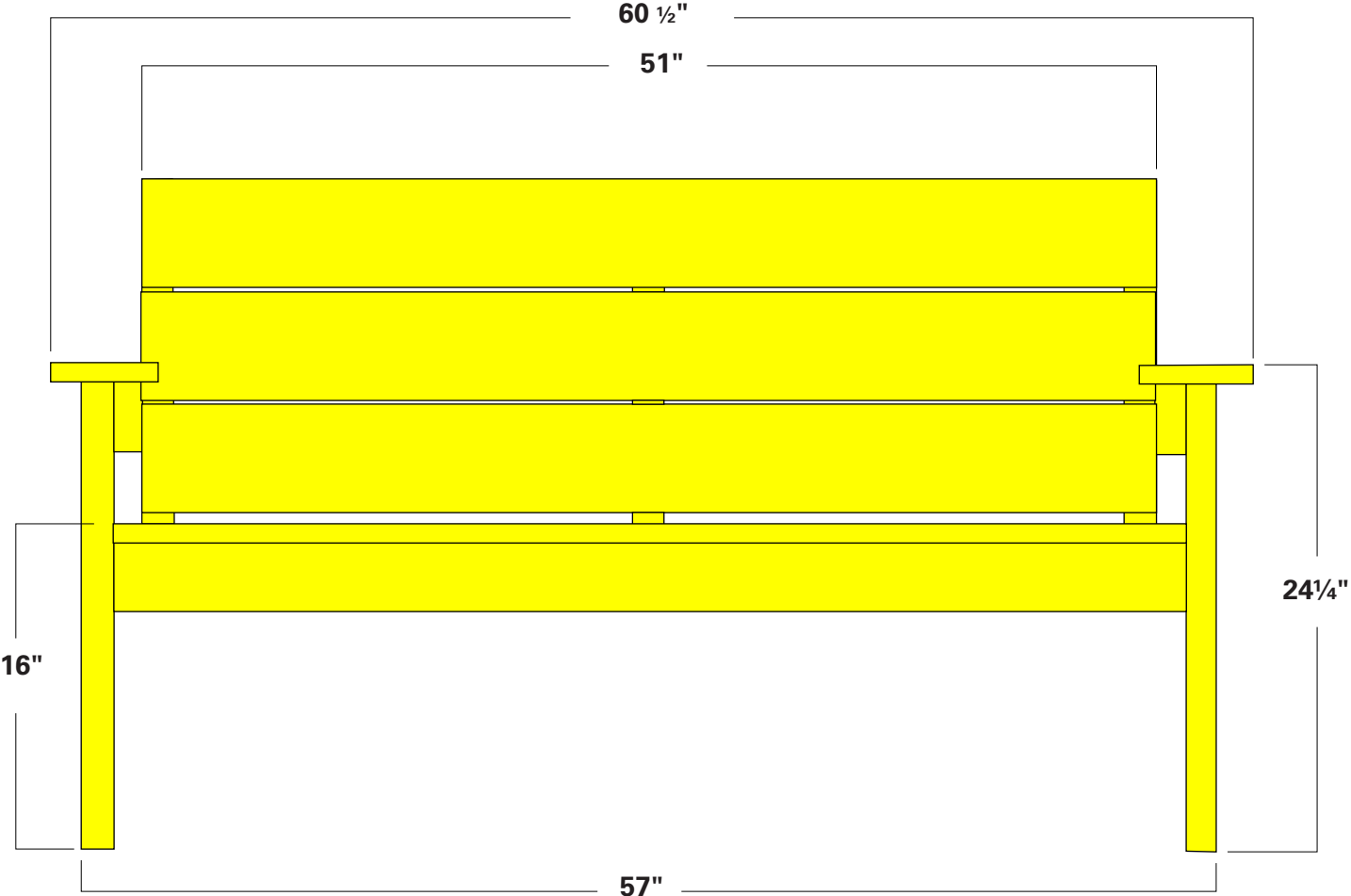

Garden Bench

YellaWood
Pressure Treated Pine

BUILDING STEPS

- 01** Cut the seat frame components (D and E) according to the dimensions on the cut list.



- 02** Arrange these pieces on your assembly table, keeping the outside of the frame ends flush with the ends of the front and back frame. Drill pilot holes and attach with 3" deck screws. You may find it helpful to clamp these pieces together as you attach them.

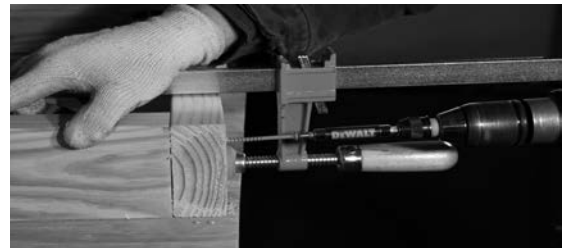

- 03** Measure and mark the center of the seat frame front and back and place the two middle stretchers so that the mark is centered within a 1 1/2" gap between stretchers. This is where the middle back support will be sandwiched, so you may want to place a piece of scrap 2x stock centered on your center mark as you attach the stretchers with 3" deck screws.



- 04** Cut three seat slats (F) and place them on your seat frame assembly. Place the rear slat first, starting it 7" from the back of the seat frame. Place 1/4" spacers between the slats, which should leave the front slat overhanging the front of the seat frame by about 1". Drill pilot holes and attach the slats with glue and 2" screws.



- 05** Lay out and cut three back supports (G) according to the detail drawing on the illustration. Make your cuts with a jigsaw or circular saw and use a straightedge guide if needed.



BUILDING STEPS

- 06** Cut the three back slats (H) to length. Place your back supports on their back edges on your assembly table and place one slat so the top edge is flush with the top of the supports. The ends of the slat should be flush with the outside edges of your supports. Measure and mark the center of your slat and center the middle support there, again keeping the top edges flush. Attach with glue and 2" screws. Repeat with the remaining two back slats, keeping $\frac{1}{4}$ " spacing between all slats.

TIP: If you like, rout a $\frac{1}{8}$ " or $\frac{1}{4}$ " roundover edge on the front seat slat and the top back slat before proceeding to the next step.



- 07** Slide the back supports into place inside the seat frame assembly, sandwiching the middle support between the two middle stretchers. Attach with 3" screws through the frame ends and stretchers and into the back supports.



- 08** Cut the four legs (A) and two arm supports (B) according to the dimensions on the cut list.



Garden Bench

YellaWood
Pressure Treated Pine

BUILDING STEPS

- 09** Lay an arm support on a pair of legs, keeping the tops and outside edges flush and attach with glue and 2 ½" screws. Repeat for other leg assembly.



- 10** Clamp the leg assemblies to the seat frame, keeping the arm supports facing inward, outer edges of the legs flush with the front and back of the seat frame, and the top of the seat slats 16" up from the bottom of the legs. Fasten with glue and 2 ½" screws.



- 11** Cut two arms (C) according to the length on the cut list. Refer to detail drawing to lay out the shape and cut with jigsaw.



- 12** Place the arms on top of the arm supports, keeping the back of the arms flush with the back edges of the back legs. The notch should fit snugly against the seat back and the front of the arm should overhang the front of the arm support by about ¾". Fasten with glue and 2" screws.



- 13** Sand all surfaces and break all edges with sandpaper and apply a weatherproof finish.



Garden Bench

FASTENER & HARDWARE INFORMATION

YellaWood®
Pressure Treated Pine

FOR INTERIOR OR EXTERIOR APPLICATIONS

Use fasteners and hardware that are in compliance with the manufacturer's recommendations and the building codes for their intended use. As with any good design and construction practices, treated wood should not be used in applications where trapped moisture or water can occur. Where design and/or actual conditions allow for constant, repetitive or long periods of wet conditions, only stainless steel fasteners should be used.

FOR EXTERIOR APPLICATIONS

The following minimum galvanization levels may be used for connectors, joist hangers, fasteners and other hardware that are placed in direct contact with exterior applications of micronized copper treated wood:

- **Fasteners** – nails, screws, etc. ASTM – A 153 (1 oz/ft²)
- **Hardware** – connectors, joist hangers, etc. ASTM – A 653 G90 (0.90 oz/ft²)

The effects of other building materials within a given assembly, along with environmental factors, should also be considered when selecting the appropriate hardware and fasteners to use for a given project containing treated wood.

Stainless Steel fasteners and hardware are required for Permanent Wood Foundations below grade and are recommended for use with treated wood in other severe exterior applications such as swimming pools, salt water exposure, etc. Type 304 and 316 are recommended grades to use.

ALUMINUM

Aluminum building products may be placed in direct contact with YellaWood® brand products used for interior uses and above ground exterior applications such as decks, fencing, and landscaping projects. Examples of aluminum products include siding, roofing, gutters, door and window trim, flashing, nails, fasteners and other hardware connectors. However, direct contact of treated products and aluminum building products should be limited to code-compliant construction applications that provide proper water drainage and do not allow the wood to be exposed to standing water or water immersion.

We recommend you contact the aluminum building products manufacturer for its recommendations regarding use of its aluminum products in contact with treated wood in ground contact applications or when exposed to salt water, brackish water, or chlorinated water, such as swimming pools or hot tubs.

Also check with the aluminum building products manufacturer regarding compatibility with other chemicals and cleaning agents and the use of their aluminum products in commercial, industrial, and specialty applications such as boat construction.

YellaWood® brand pressure treated products are treated with preservatives (the "Preservatives") and preservative methods, systems, and technologies of unrelated third parties. For details regarding the Preservatives, methods, systems, and technologies used by Great Southern Wood Preserving, Incorporated, see www.yellowood.com/preservative or write us at P.O. Box 610, Abbeville, AL 36310. Ask dealer for warranty details. For warranty or for important handling and other information concerning our products including the appropriate Material Safety Data Sheet (MSDS), please visit us at www.yellowood.com/warranties or write us at P.O. Box 610, Abbeville, AL 36310. YellaWood® and the yellow tag are federally registered trademarks of Great Southern Wood Preserving, Incorporated.

Great Southern Wood Preserving, Incorporated makes no warranties expressed or implied as to the fitness for a particular purpose of this plan.

Garden Bench

IMPORTANT INFORMATION

YellaWood®
Pressure Treated Pine

- Consult the end tag to determine which preservative or preservative system was used in the treatment of that particular product. YellaWood® brand products may be used in direct contact with aluminum building products when limited to code-compliant construction applications that provide proper water drainage and do not allow the wood to be exposed to standing water or water immersion.
- Use fasteners and other hardware that are in compliance with building codes for the intended use.
- Do not burn preserved wood.
- Wear a dust mask and goggles when cutting or sanding wood.
- Wear gloves when working with wood.
- Some preservative may migrate from the treated wood into soil/water or may dislodge from the treated wood surface upon contact with skin.
- Wash exposed skin areas thoroughly.
- All sawdust and construction debris should be cleaned up and disposed of after construction.
- Wash work clothes separately from other household clothing before reuse.
- Preserved wood should not be used where it may come into direct or indirect contact with drinking water, except for uses involving incidental contact such as fresh water docks and bridges.
- Do not use preserved wood under circumstances when the preservative may become a component of food, animal feed or beehives.
- Do not use preserved wood as mulch.
- Only preserved wood that is visibly clean and free of surface residue should be used. If the wood is to be used in an interior application and becomes wet during construction, it should be allowed to dry before being covered or enclosed.
- Mold growth can and does occur on the surface of many products, including untreated and treated wood, during prolonged surface exposure to excessive moisture conditions. To remove mold from the treated wood surface, wood should be allowed to dry. Typically, mild soap and water can be used to remove remaining surface mold. For more information visit www.epa.gov.
- Projects should be designed and installed in accordance with federal, state and local building codes and ordinances governing construction in your area, and in accordance with the National Design Specifications (NDS) and the Wood Handbook.

DISPOSAL RECOMMENDATIONS

Preserved wood may be disposed of in landfills or burned in commercial or industrial incinerators or boilers in accordance with federal, state and local regulations.